

**TEST PAPER OF JEE(MAIN) EXAMINATION – 2019**  
**(Held On Friday 11<sup>th</sup> JANUARY, 2019) TIME : 02 : 30 PM To 05 : 30 PM**  
**PHYSICS**

1. A paramagnetic substance in the form of a cube with sides 1 cm has a magnetic dipole moment of  $20 \times 10^{-6}$  J/T when a magnetic intensity of  $60 \times 10^3$  A/m is applied. Its magnetic susceptibility is :-

- (1)  $2.3 \times 10^{-2}$                       (2)  $3.3 \times 10^{-2}$   
(3)  $3.3 \times 10^{-4}$                       (4)  $4.3 \times 10^{-2}$

Ans. (3)

Sol.  $\chi = \frac{I}{H}$

$$I = \frac{\text{Magnetic moment}}{\text{Volume}}$$

$$I = \frac{20 \times 10^{-6}}{10^{-6}} = 20 \text{ N/m}^2$$

$$\chi = \frac{20}{60 \times 10^3} = \frac{1}{3} \times 10^{-3}$$

$$= 0.33 \times 10^{-3} = 3.3 \times 10^{-4}$$

2. A particle of mass  $m$  is moving in a straight line with momentum  $p$ . Starting at time  $t = 0$ , a force  $F = kt$  acts in the same direction on the moving particle during time interval  $T$  so that its momentum changes from  $p$  to  $3p$ . Here  $k$  is a constant. The value of  $T$  is :-

- (1)  $2\sqrt{\frac{p}{k}}$     (2)  $\sqrt{\frac{2p}{k}}$     (3)  $\sqrt{\frac{2k}{p}}$     (4)  $2\sqrt{\frac{k}{p}}$

Ans. (1)

Sol.  $\frac{dp}{dt} = F = kt$

$$\int_p^{3p} dP = \int_0^T kt \, dt$$

$$2p = \frac{KT^2}{2}$$

$$T = 2\sqrt{\frac{p}{K}}$$

3. Seven capacitors, each of capacitance  $2 \mu\text{F}$ , are to be connected in a configuration to obtain an effective capacitance of  $\left(\frac{6}{13}\right) \mu\text{F}$ . Which of

the combinations, shown in figures below, will achieve the desired value ?

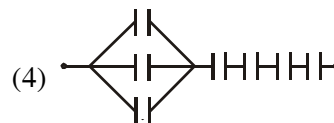
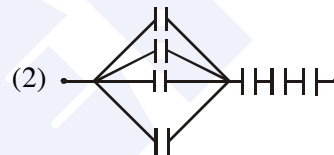
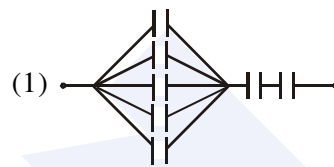

Ans. (4)

Sol.  $C_{eq} = \frac{6}{13} \mu\text{F}$

Therefore three capacitors must be in parallel to get 6 in

$$\frac{1}{C_{eq}} = \frac{1}{3C} + \frac{1}{C} + \frac{1}{C} + \frac{1}{C} + \frac{1}{C}$$

$$C_{eq} = \frac{3C}{13} = \frac{6}{13} \mu\text{F}$$

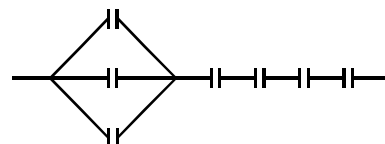

4. An electric field of 1000 V/m is applied to an electric dipole at angle of 45°. The value of electric dipole moment is 10<sup>-29</sup> C.m. What is the potential energy of the electric dipole ?  
 (1) - 9 × 10<sup>-20</sup> J  
 (2) - 7 × 10<sup>-27</sup> J  
 (3) - 10 × 10<sup>-29</sup> J  
 (4) - 20 × 10<sup>-18</sup> J

Ans. (2)

Sol.  $U = -\vec{p} \cdot \vec{E}$   
 $= -PE \cos \theta$   
 $= -(10^{-29})(10^3) \cos 45^\circ$   
 $= -0.707 \times 10^{-26} \text{ J}$   
 $= -7 \times 10^{-27} \text{ J}$

5. A simple pendulum of length 1 m is oscillating with an angular frequency 10 rad/s. The support of the pendulum starts oscillating up and down with a small angular frequency of 1 rad/s and an amplitude of 10<sup>-2</sup> m. The relative change in the angular frequency of the pendulum is best given by :-  
 (1) 10<sup>-3</sup> rad/s  
 (2) 10<sup>-1</sup> rad/s  
 (3) 1 rad/s  
 (4) 10<sup>-5</sup> rad/s

Ans. (1)

Sol. Angular frequency of pendulum

$$\omega = \sqrt{\frac{g_{\text{eff}}}{\ell}}$$

$$\therefore \frac{\Delta\omega}{\omega} = \frac{1}{2} \frac{\Delta g_{\text{eff}}}{g_{\text{eff}}}$$

$$\Delta\omega = \frac{1}{2} \frac{\Delta g}{g} \times \omega$$

[ $\omega_s$  = angular frequency of support]

$$\Delta\omega = \frac{1}{2} \times \frac{2A\omega_s^2}{100} \times 100$$

$$\Delta\omega = 10^{-3} \text{ rad/sec.}$$

6. Two rods A and B of identical dimensions are at temperature 30°C. If A is heated upto 180°C and B upto T°C, then the new lengths are the same. If the ratio of the coefficients of linear expansion of A and B is 4 : 3, then the value of T is :-

- (1) 270°C (2) 230°C  
 (3) 250°C (4) 200°C

Ans. (2)

Sol.  $\Delta\ell_1 = \Delta\ell_2$   
 $\ell\alpha_1\Delta T_1 = \ell\alpha_2\Delta T_2$   
 $\frac{\alpha_1}{\alpha_2} = \frac{\Delta T_1}{\Delta T_2}$

$$\frac{4}{3} = \frac{T - 30}{180 - 30}$$

$$T = 230^\circ\text{C}$$

7. In a double-slit experiment, green light (5303 Å) falls on a double slit having a separation of 19.44 μm and a width of 4.05 μm. The number of bright fringes between the first and the second diffraction minima is :-  
 (1) 09 (2) 10  
 (3) 04 (4) 05

Ans. (4)

Sol. For diffraction

location of 1<sup>st</sup> minime

$$y_1 = \frac{D\lambda}{a} = 0.2469D\lambda$$

location of 2<sup>nd</sup> minima

$$y_2 = \frac{2D\lambda}{a} = 0.4938D\lambda$$

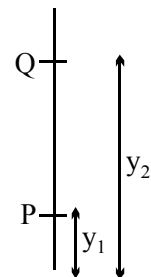

Now for interference

Path difference at P.

$$\frac{dy}{D} = 4.8\lambda$$

path difference at Q

$$\frac{dy}{D} = 9.6\lambda$$

So orders of maxima in between P & Q is

5, 6, 7, 8, 9

So 5 bright fringes all present between P & Q.

8. An amplitude modulated signal is plotted below :-

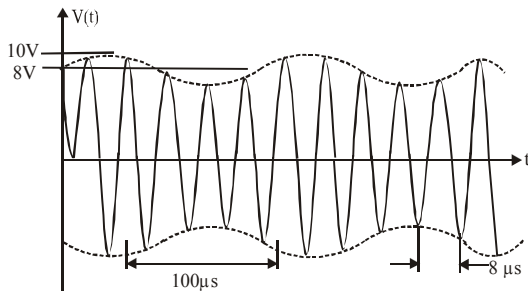

Which one of the following best describes the above signal ?

- (1)  $(9 + \sin(2.5\pi \times 10^5 t)) \sin(2\pi \times 10^4 t)V$   
 (2)  $(9 + \sin(4\pi \times 10^4 t)) \sin(5\pi \times 10^5 t)V$   
 (3)  $(1 + 9\sin(2\pi \times 10^4 t)) \sin(2.5\pi \times 10^5 t)V$   
 (4)  $(9 + \sin(2\pi \times 10^4 t)) \sin(2.5\pi \times 10^5 t)V$

**Ans. (4)**

**Sol.** Analysis of graph says

- (1) Amplitude varies as  $8 - 10$  V or  $9 \pm 1$   
 (2) Two time period as  
 $100 \mu\text{s}$  (signal wave) &  $8 \mu\text{s}$  (carrier wave)

$$\text{Hence signal is } \left[ 9 \pm 1 \sin\left(\frac{2\pi t}{T_1}\right) \right] \sin\left(\frac{2\pi t}{T_2}\right)$$

$$= 9 \pm 1 \sin(2\pi \times 10^4 t) \sin 2.5\pi \times 10^5 t$$

9. In the circuit, the potential difference between A and B is :-

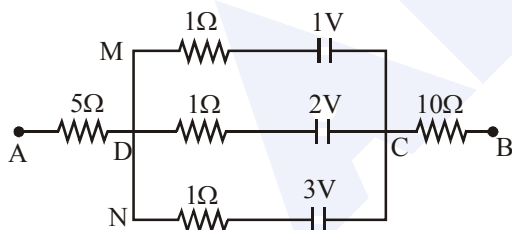

- (1) 6 V    (2) 1 V    (3) 3 V    (4) 2 V

**Ans. (4)**

**Sol.** Potential difference across AB will be equal to battery equivalent across CD

$$V_{AB} = V_{CD} = \frac{\frac{E_1}{r_1} + \frac{E_2}{r_2} + \frac{E_3}{r_3}}{\frac{1}{r_1} + \frac{1}{r_2} + \frac{1}{r_3}} = \frac{\frac{1}{1} + \frac{2}{1} + \frac{3}{1}}{\frac{1}{1} + \frac{1}{1} + \frac{1}{1}}$$

$$= \frac{6}{3} = 2V$$

10. A 27 mW laser beam has a cross-sectional area of  $10 \text{ mm}^2$ . The magnitude of the maximum electric field in this electromagnetic wave is given by [Given permittivity of space  $\epsilon_0 = 9 \times 10^{-12}$  SI units, Speed of light  $c = 3 \times 10^8$  m/s]:-

- (1) 1 kV/m                      (2) 2 kV/m  
 (3) 1.4 kV/m                    (4) 0.7 kV/m

**Ans. (3)**

**Sol.** Intensity of EM wave is given by

$$I = \frac{\text{Power}}{\text{Area}} = \frac{1}{2} \epsilon_0 E_0^2 C$$

$$= \frac{27 \times 10^{-3}}{10 \times 10^{-6}} = \frac{1}{2} \times 9 \times 10^{-12} \times E^2 \times 3 \times 10^8$$

$$E = \sqrt{2} \times 10^3 \text{ kv/m} \\ = 1.4 \text{ kv/m}$$

11. A pendulum is executing simple harmonic motion and its maximum kinetic energy is  $K_1$ . If the length of the pendulum is doubled and it performs simple harmonic motion with the same amplitude as in the first case, its maximum kinetic energy is  $K_2$ . Then :-

- (1)  $K_2 = \frac{K_1}{4}$                       (2)  $K_2 = \frac{K_1}{2}$   
 (3)  $K_2 = 2K_1$                     (4)  $K_2 = K_1$

**Ans. (3)**

**Sol.** Maximum kinetic energy at lowest point B is given by

$$K = mgl(1 - \cos \theta)$$

where  $\theta =$  angular amp.

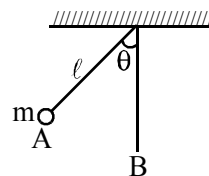

$$K_1 = mg\ell(1 - \cos \theta)$$

$$K_2 = mg(2\ell)(1 - \cos \theta)$$

$$K_2 = 2K_1.$$

12. In a hydrogen like atom, when an electron jumps from the M - shell to the L - shell, the wavelength of emitted radiation is  $\lambda$ . If an electron jumps from N-shell to the L-shell, the wavelength of emitted radiation will be :-

- (1)  $\frac{27}{20}\lambda$     (2)  $\frac{16}{25}\lambda$     (3)  $\frac{20}{27}\lambda$     (4)  $\frac{25}{16}\lambda$

Ans. (3)

Sol. For M  $\rightarrow$  L steel

$$\frac{1}{\lambda} = K \left( \frac{1}{2^2} - \frac{1}{3^2} \right) = \frac{K \times 5}{36}$$

for N  $\rightarrow$  L

$$\frac{1}{\lambda'} = K \left( \frac{1}{2^2} - \frac{1}{4^2} \right) = \frac{K \times 3}{16}$$

$$\lambda' = \frac{20}{27}\lambda$$

13. If speed (V), acceleration (A) and force (F) are considered as fundamental units, the dimension of Young's modulus will be :-

- (1)  $V^{-2} A^2 F^2$                       (2)  $V^{-4} A^2 F$   
 (3)  $V^{-4} A^{-2} F$                       (4)  $V^{-2} A^2 F^{-2}$

Ans. (2)

Sol.  $\frac{F}{A} = y \cdot \frac{\Delta \ell}{\ell}$

$$[Y] = \frac{F}{A}$$

Now from dimension

$$F = \frac{ML}{T^2}$$

$$L = \frac{F}{M} \cdot T^2$$

$$L^2 = \frac{F^2}{M^2} \left( \frac{V}{A} \right)^4 \quad \therefore T = \frac{V}{A}$$

$$L^2 = \frac{F^2}{M^2 A^2} \frac{V^4}{A^2} \quad F = MA$$

$$L^2 = \frac{V^4}{A^2}$$

$$[Y] = \frac{[F]}{[A]} = F^1 V^{-4} A^2$$

14. A particle moves from the point  $(2.0\hat{i} + 4.0\hat{j})$  m, at  $t = 0$ , with an initial velocity  $(5.0\hat{i} + 4.0\hat{j})$   $\text{ms}^{-1}$ .

It is acted upon by a constant force which produces a constant acceleration  $(4.0\hat{i} + 4.0\hat{j})$   $\text{ms}^{-2}$ . What is the distance of the particle from the origin at time 2 s ?

- (1)  $20\sqrt{2}$  m                      (2)  $10\sqrt{2}$  m  
 (3) 5 m                                  (4) 15 m

Ans. (1)

Sol.  $\vec{S} = (5\hat{i} + 4\hat{j})2 + \frac{1}{2}(4\hat{i} + 4\hat{j})4$

$$= 10\hat{i} + 8\hat{j} + 8\hat{i} + 8\hat{j}$$

$$\vec{r}_f - \vec{r}_i = 18\hat{i} + 16\hat{j}$$

$$\vec{r}_f = 20\hat{i} + 20\hat{j}$$

$$|\vec{r}_f| = 20\sqrt{2}$$

15. A monochromatic light is incident at a certain angle on an equilateral triangular prism and suffers minimum deviation. If the refractive index of the material of the prism is  $\sqrt{3}$ , then the angle of incidence is :-

- (1)  $30^\circ$                                   (2)  $45^\circ$   
 (3)  $90^\circ$                                   (4)  $60^\circ$

Ans. (4)

Sol.  $i = e$

$$r_1 = r_2 = \frac{A}{2} = 30^\circ$$

by Snell's law

$$1 \times \sin i = \sqrt{3} \times \frac{1}{2} = \frac{\sqrt{3}}{2}$$

$$i = 60$$

16. A galvanometer having a resistance of  $20 \Omega$  and 30 divisions on both sides has figure of merit 0.005 ampere/division. The resistance that should be connected in series such that it can be used as a voltmeter upto 15 volt, is :-

- (1)  $80 \Omega$                                   (2)  $120 \Omega$   
 (3)  $125 \Omega$                                   (4)  $100 \Omega$

**Ans. (1)**

**Sol.**  $R_g = 20\Omega$

$N_L = N_R = N = 30$

FOM =  $\frac{I}{\phi} = 0.005 \text{ A/Div.}$

Current sensitivity = CS =  $\left(\frac{1}{0.005}\right) = \frac{\phi}{I}$

$I_{g_{\max}} = 0.005 \times 30$   
 $= 15 \times 10^{-2} = 0.15$

$15 = 0.15 [20 + R]$

$100 = 20 + R$

$R = 80$

- 17.** The circuit shown below contains two ideal diodes, each with a forward resistance of  $50\Omega$ . If the battery voltage is  $6 \text{ V}$ , the current through the  $100 \Omega$  resistance (in Amperes) is :-

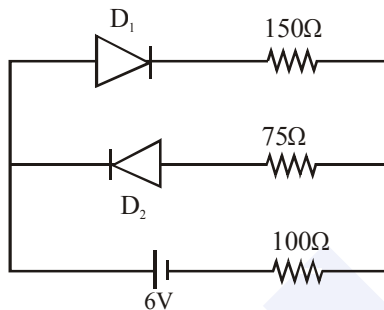

(1) 0.027

(2) 0.020

(3) 0.030

(4) 0.036

**Ans. (2)**

**Sol.**  $I = \frac{6}{300} = 0.002$  ( $D_2$  is in reverse bias)

- 18.** When  $100 \text{ g}$  of a liquid A at  $100^\circ\text{C}$  is added to  $50 \text{ g}$  of a liquid B at temperature  $75^\circ\text{C}$ , the temperature of the mixture becomes  $90^\circ\text{C}$ . The temperature of the mixture, if  $100 \text{ g}$  of liquid A at  $100^\circ\text{C}$  is added to  $50 \text{ g}$  of liquid B at  $50^\circ\text{C}$ , will be :-

(1)  $80^\circ\text{C}$

(2)  $60^\circ\text{C}$

(3)  $70^\circ\text{C}$

(4)  $85^\circ\text{C}$

**Ans. (1)**

**Sol.**  $100 \times S_A \times [100 - 90] = 50 \times S_B \times (90 - 75)$

$2S_A = 1.5 S_B$

$S_A = \frac{3}{4} S_B$

Now,  $100 \times S_A \times [100 - T] = 50 \times S_B (T - 50)$

$2 \times \left(\frac{3}{4}\right) (100 - T) = (T - 50)$

$300 - 3T = 2T - 100$

$400 = 5T$

$T = 80$

- 19.** The mass and the diameter of a planet are three times the respective values for the Earth. The period of oscillation of a simple pendulum on the Earth is  $2 \text{ s}$ . The period of oscillation of the same pendulum on the planet would be :-

(1)  $\frac{2}{\sqrt{3}} \text{ s}$

(2)  $2\sqrt{3} \text{ s}$

(3)  $\frac{\sqrt{3}}{2} \text{ s}$

(4)  $\frac{3}{2} \text{ s}$

**Ans. (2)**

**Sol.**  $\therefore g = \frac{GM}{R^2}$

$\frac{g_p}{g_e} = \frac{M_e \left(\frac{R_e}{R_p}\right)^2}{M_e \left(\frac{R_e}{R_p}\right)^2} = 3 \left(\frac{1}{3}\right)^2 = \frac{1}{3}$

Also  $T \propto \frac{1}{\sqrt{g}}$

$\Rightarrow \frac{T_p}{T_e} = \sqrt{\frac{g_e}{g_p}} = \sqrt{3}$

$\Rightarrow T_p = 2\sqrt{3} \text{ s}$

- 20.** The region between  $y = 0$  and  $y = d$  contains a magnetic field  $\vec{B} = B\hat{z}$ . A particle of mass  $m$  and charge  $q$  enters the region with a velocity

$\vec{v} = v\hat{i}$ . If  $d = \frac{mv}{2qB}$ , the acceleration of the

charged particle at the point of its emergence at the other side is :-

(1)  $\frac{qvB}{m} \left( \frac{\hat{i} + \hat{j}}{\sqrt{2}} \right)$

(2)  $\frac{qvB}{m} \left( \frac{1}{2}\hat{i} - \frac{\sqrt{3}}{\sqrt{2}}\hat{j} \right)$

(3)  $\frac{qvB}{m} \left( \frac{-\hat{j} + \hat{i}}{\sqrt{2}} \right)$

(4)  $\frac{qvB}{m} \left( \frac{\sqrt{3}}{2}\hat{i} + \frac{1}{2}\hat{j} \right)$

Ans. (BONUS)

21. A thermometer graduated according to a linear scale reads a value  $x_0$  when in contact with boiling water, and  $x_0/3$  when in contact with ice. What is the temperature of an object in  $0^\circ\text{C}$ , if this thermometer in the contact with the object reads  $x_0/2$  ?

- (1) 35
- (2) 25
- (3) 60
- (4) 40

Ans. (2)

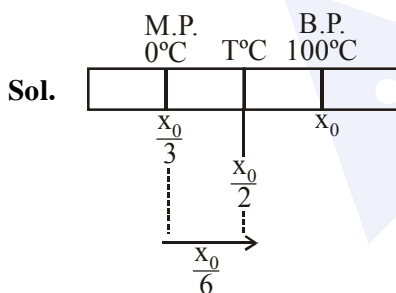

$\Rightarrow T^\circ\text{C} = \frac{x_0}{6} \text{ \& \ } \left( x_0 - \frac{x_0}{3} \right) = (100 - 0^\circ\text{C})$

$x_0 = \frac{300}{2}$

$\Rightarrow T^\circ\text{C} = \frac{150}{6} = 25^\circ\text{C}$

22. A string is wound around a hollow cylinder of mass 5 kg and radius 0.5 m. If the string is now pulled with a horizontal force of 40 N, and the cylinder is rolling without slipping on a horizontal surface (see figure), then the angular acceleration of the cylinder will be (Neglect the mass and thickness of the string) :-

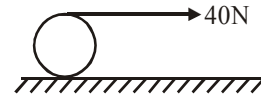

- (1) 12 rad/s<sup>2</sup>
- (2) 16 rad/s<sup>2</sup>
- (3) 10 rad/s<sup>2</sup>
- (4) 20 rad/s<sup>2</sup>

Ans. (2)

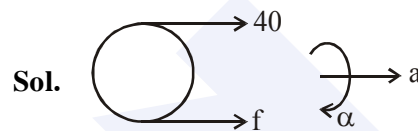

Sol.

$40 + f = m(R\alpha) \dots\dots(i)$   
 $40 \times R - f \times R = mR^2\alpha$   
 $40 - f = mR\alpha \dots\dots (ii)$   
 From (i) and (ii)

$\alpha = \frac{40}{mR} = 16$

23. In a process, temperature and volume of one mole of an ideal monoatomic gas are varied according to the relation  $VT = K$ , where K is a constant. In this process the temperature of the gas is increased by  $\Delta T$ . The amount of heat absorbed by gas is (R is gas constant) :

- (1)  $\frac{1}{2}R\Delta T$
- (2)  $\frac{3}{2}R\Delta T$
- (3)  $\frac{1}{2}KR\Delta T$
- (4)  $\frac{2K}{3}\Delta T$

Ans. (1)

Sol.  $VT = K$

$\Rightarrow V \left( \frac{PV}{nR} \right) = k \Rightarrow PV^2 = K$

$\therefore C = \frac{R}{1-x} + C_v$  (For polytropic process)

$C = \frac{R}{1-2} + \frac{3R}{2} = \frac{R}{2}$

$\therefore \Delta Q = nC \Delta T$

$$= \frac{R}{2} \times \Delta T$$

- 24.** In a photoelectric experiment, the wavelength of the light incident on a metal is changed from 300 nm to 400 nm. The decrease in the stopping

potential is close to :  $\left( \frac{hc}{e} = 1240 \text{ nm} - V \right)$

- (1) 0.5 V (2) 1.0 V  
(3) 2.0 V (4) 1.5 V

**Ans. (2)**

**Sol.**  $\frac{hc}{\lambda_1} = \phi + eV_1$  ..... (i)

$\frac{hc}{\lambda_2} = \phi + eV_2$  ..... (ii)

(i) - (ii)

$$hc \left( \frac{1}{\lambda_1} - \frac{1}{\lambda_2} \right) = e(V_1 - V_2)$$

$$\Rightarrow V_1 - V_2 = \frac{hc}{e} \left( \frac{\lambda_2 - \lambda_1}{\lambda_1 \lambda_2} \right)$$

$$= (1240 \text{ nm} - V) \frac{100 \text{ nm}}{300 \text{ nm} \times 400 \text{ nm}}$$

$$= 1 \text{ V}$$

- 25.** A metal ball of mass 0.1 kg is heated upto 500°C and dropped into a vessel of heat capacity 800 JK<sup>-1</sup> and containing 0.5 kg water. The initial temperature of water and vessel is 30°C. What is the approximate percentage increment in the temperature of the water ? [Specific Heat Capacities of water and metal are, respectively, 4200 Jkg<sup>-1</sup>K<sup>-1</sup> and 400 Jkg<sup>-1</sup>K<sup>-1</sup>]

- (1) 30% (2) 20%  
(3) 25% (4) 15%

**Ans. (2)**

**Sol.**  $0.1 \times 400 \times (500 - T) = 0.5 \times 4200 \times (T - 30) + 800 (T - 30)$

$$\Rightarrow 40(500 - T) = (T - 30) (2100 + 800)$$

$$\Rightarrow 20000 - 40T = 2900 T - 30 \times 2900$$

$$\Rightarrow 20000 + 30 \times 2900 = T(2940)$$

$$T = 30.4^\circ\text{C}$$

$$\frac{\Delta T}{T} \times 100 = \frac{6.4}{30} \times 100$$

$$\approx 20\%$$

- 26.** The magnitude of torque on a particle of mass 1kg is 2.5 Nm about the origin. If the force acting on it is 1 N, and the distance of the particle from the origin is 5m, the angle between the force and the position vector is (in radians) :-

- (1)  $\frac{\pi}{8}$  (2)  $\frac{\pi}{6}$  (3)  $\frac{\pi}{4}$  (4)  $\frac{\pi}{3}$

**Ans. (2)**

**Sol.**  $2.5 = 1 \times 5 \sin \theta$

$$\sin \theta = 0.5 = \frac{1}{2}$$

$$\theta = \frac{\pi}{6}$$

- 27.** In the experimental set up of metre bridge shown in the figure, the null point is obtained at a distance of 40 cm from A. If a 10Ω resistor is connected in series with R<sub>1</sub>, the null point shifts by 10 cm. The resistance that should be connected in parallel with (R<sub>1</sub> + 10)Ω such that the null point shifts back to its initial position is

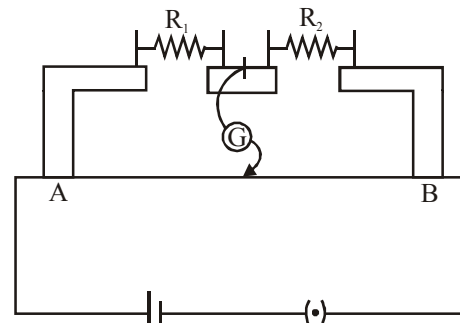

- (1) 40 Ω (2) 60 Ω (3) 20 Ω (4) 30 Ω

**MAJOR COMPUTER BASED TEST (CBT) SERIES**

**JEE (Advanced)- Target 2019**

**dlp.allen.ac.in** Test Dates: 3<sup>rd</sup> Feb, 21<sup>st</sup> & 28<sup>th</sup> April, 12<sup>th</sup> May **0744-2750275**

Ans. (2)

Sol.  $\frac{R_1}{R_2} = \frac{2}{3}$  .....(i)

$$\frac{R_1 + 10}{R_2} = 1 \Rightarrow R_1 + 10 = R_2 \quad \text{.....(ii)}$$

$$\frac{2R_2}{3} + 10 = R_2$$

$$10 = \frac{R_2}{3} \Rightarrow R_2 = 30\Omega$$

&  $R_1 = 20\Omega$

$$\frac{30 \times R}{30 + R} = \frac{2}{3}$$

$R = 60 \Omega$

28. A circular disc  $D_1$  of mass  $M$  and radius  $R$  has two identical discs  $D_2$  and  $D_3$  of the same mass  $M$  and radius  $R$  attached rigidly at its opposite ends (see figure). The moment of inertia of the system about the axis  $OO'$ , passing through the centre of  $D_1$ , as shown in the figure, will be:-

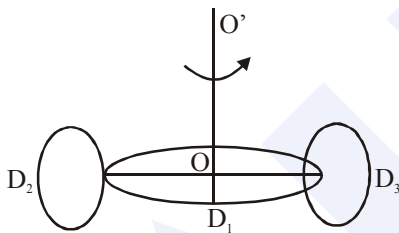

- (1)  $3MR^2$                       (2)  $\frac{2}{3}MR^2$   
 (3)  $MR^2$                       (4)  $\frac{4}{5}MR^2$

Ans. (1)

Sol.  $I = \frac{MR^2}{2} + 2\left(\frac{MR^2}{4} + MR^2\right)$   
 $= \frac{MR^2}{2} + \frac{MR^2}{2} + 2MR^2$   
 $= 3MR^2$

29. A copper wire is wound on a wooden frame, whose shape is that of an equilateral triangle. If the linear dimension of each side of the frame is increased by a factor of 3, keeping the number of turns of the coil per unit length of the frame the same, then the self inductance of the coil :

- (1) Decreases by a factor of  $9\sqrt{3}$   
 (2) Increases by a factor of 3  
 (3) Decreases by a factor of 9  
 (4) Increases by a factor of 27

Ans. (2)

Sol. Total length  $L$  will remain constant  
 $L = (3a) N$  ( $N =$  total turns)  
 and length of winding =  $(d) N$   
 ( $d =$  diameter of wire)

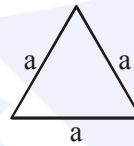

self inductance =  $\mu_0 n^2 A \ell$   
 $= \mu_0 n^2 \left(\frac{\sqrt{3} a^2}{4}\right) dN$   
 $\propto a^2 N \propto a$   
 So self inductance will become 3 times

30. A particle of mass  $m$  and charge  $q$  is in an electric and magnetic field given by

$$\vec{E} = 2\hat{i} + 3\hat{j} ; \vec{B} = 4\hat{j} + 6\hat{k}.$$

The charged particle is shifted from the origin to the point  $P(x = 1 ; y = 1)$  along a straight path. The magnitude of the total work done is :-

- (1)  $(0.35)q$                       (2)  $(0.15)q$   
 (3)  $(2.5)q$                       (4)  $5q$

Ans. (4)

Sol.  $\vec{F}_{net} = q\vec{E} + q(\vec{v} \times \vec{B})$   
 $= (2q\hat{i} + 3q\hat{j}) + q(\vec{v} \times \vec{B})$   
 $W = \vec{F}_{net} \cdot \vec{S}$   
 $= 2q + 3q$   
 $= 5q$

## MAJOR COMPUTER BASED TEST (CBT) SERIES

JEE (Main)- Target 2019