

FIITJEE

Solutions to JEE(Main)-2019

Test Date: 12th January 2019 (Second Shift)

PHYSICS, CHEMISTRY & MATHEMATICS

Paper - 1

Time Allotted: 3 Hours

Maximum Marks: 360

- Please read the instructions carefully. You are allotted 5 minutes specifically for this purpose.

Important Instructions:

1. The test is of **3 hours** duration.
2. This **Test Paper** consists of **90** questions. The maximum marks are **360**.
3. There are **three** parts in the question paper A, B, C consisting of **Physics, Chemistry** and **Mathematics** having 30 questions in each part of equal weightage. Each question is allotted **4 (four)** marks for correct response.
4. Out of the four options given for each question, only one option is the correct answer.
5. For each incorrect response 1 mark i.e. $\frac{1}{4}$ (**one-fourth**) marks of the total marks allotted to the question will be deducted from the total score. No deduction from the total score, however, will be made if no response is indicated for an item in the Answer Box.
6. *Candidates will be awarded marks as stated above in **instruction No.3** for correct response of each question. One mark will be deducted for indicating incorrect response of each question. No deduction from the total score will be made if no response is indicated for an item in the answer box.*
7. There is only one correct response for each question. Marked up more than one response in any question will be treated as wrong response and marked up for wrong response will be deducted accordingly as per **instruction 6** above.

PART -A (PHYSICS)

1. The moment of inertia of a solid sphere, about an axis parallel to its diameter and at a distance of x from it, is ' $I(x)$ '. Which one of the graphs represents the variation of $I(x)$ with x correctly?

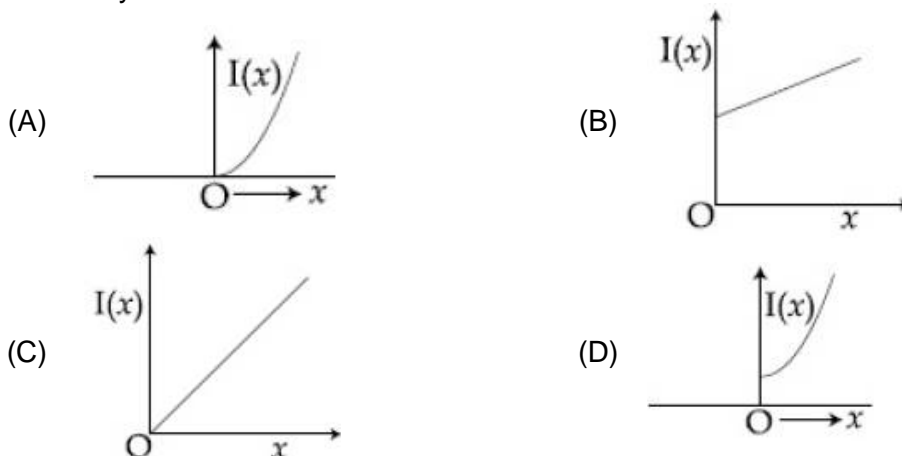

2. A load of mass M kg is suspended from a steel wire of length 2 m and radius 1.0 mm in Searle's apparatus experiment. The increase in length produced in the wire is 4.0 mm. Now the load is fully immersed in a liquid of relative density 2. The relative density of the material of load is 8. The new value of increase in length of the steel wire is:
 (A) 3.0 mm (B) 4.0 mm
 (C) 5.0 mm (D) zero

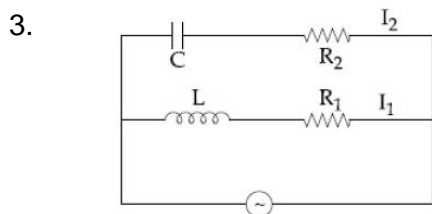

- In the above circuit, $C = \frac{\sqrt{3}}{2} \mu\text{F}$, $R = 20 \Omega$, $L = \frac{\sqrt{3}}{10} \text{H}$ and $R_1 = 10 \Omega$. Current in L- R_1 path is I_1 and C- R_2 path is I_2 . The voltage of A.C source is given by, $V = 200\sqrt{2} \sin(100t)$ volts. The phase difference between I_1 and I_2 is :
 (A) 60° (B) 30°
 (C) 90° (D) 0°

4. An ideal gas is enclosed in a cylinder at pressure of 2 atm and temperature, 300 K. The mean time between two successive collisions is 6×10^{-8} s. If the pressure is doubled and temperature is increased to 500 K, the mean time between two successive collisions will be close to :
 (A) 2×10^{-7} s (B) 4×10^{-8} s
 (C) 0.5×10^{-8} s (D) 3×10^{-6} s

5. In the figure, given that V_{BB} supply can vary from 0 to 5.0 V, $V_{CC} = 5$ V, $\beta_{dc} = 200$, $R_B = 100$, k Ω , $R_C = 1$ k Ω and $V_{BE} = 1.0$ V, The minimum base current and the input voltage at which the transistor will go to saturation, will be respectively :
- (A) 25 μ A and 3.5 V
 (B) 20 μ A and 3.5 V
 (C) 25 μ A and 2.8 V
 (D) 20 μ A and 2.8 V

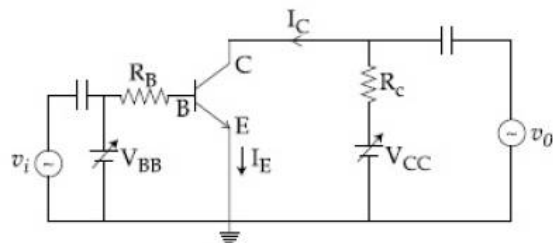

6. In the circuit shown, find C if the effective capacitance of the whole circuit is to be 0.5 μ F. All values in the circuit are in μ F.

(A) $\frac{7}{11}$ μ F

(B) $\frac{6}{5}$ μ F

(C) 4 μ F

(D) $\frac{7}{10}$ μ F

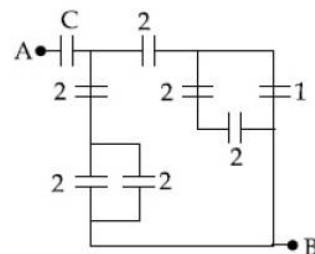

7. An alpha-particle of mass m suffers 1-dimensional elastic collision with a nucleus at rest of unknown mass. It is scattered directly backwards losing, 64% of its initial kinetic energy. The mass of the nucleus is :
- (A) 2 m (B) 3.5 m
 (C) 1.5 m (D) 4 m
8. A 10 m long horizontal wire extends from North East to South West. It is falling with a speed of 5.0 ms^{-1} , at right angles to the horizontal component of the earth's magnetic field, of 0.3×10^{-4} Wb/ m^2 . The value of the induced emf in wire is :
- (A) 1.5×10^{-3} V (B) 1.1×10^{-3} V
 (C) 2.5×10^{-3} V (D) 0.3×10^{-3} V
9. To double the covering range of a TV transition tower, its height should be multiplied by :
- (A) $\frac{1}{\sqrt{2}}$ (B) 2
 (C) 4 (D) $\sqrt{2}$
10. A plano-convex lens (focal length f_2 , refractive index μ_2 , radius of curvature R) fits exactly into a plano-concave lens (focal length f_1 , refractive index μ_1 , radius of curvature R). Their plane surfaces are parallel to each other. Then, the focal length of the combination will be :
- (A) $f_1 - f_2$ (B) $\frac{R}{\mu_2 - \mu_1}$
 (C) $\frac{2f_1 f_2}{f_1 + f_2}$ (D) $f_1 + f_2$

JEE-MAIN-2019 (12th Jan-Second Shift)-PCM-4

11. A vertical closed cylinder is separated into two parts by a frictionless piston of mass m and of negligible thickness. The piston is free to move along the length of the cylinder. The length of the cylinder above the piston is l_1 , and that below the piston is l_2 , such that $l_1 > l_2$. Each part of the cylinder contains n moles of an ideal gas at equal temperature T . If the piston is stationary, its mass, m , will be given by:

(R is universal gas constant and g is the acceleration due to gravity)

(A) $\frac{RT}{ng} \left[\frac{l_1 - 3l_2}{l_1 l_2} \right]$ (B) $\frac{RT}{g} \left[\frac{2l_1 + l_2}{l_1 l_2} \right]$
 (C) $\frac{nRT}{ng} \left[\frac{1}{l_2} + \frac{1}{l_1} \right]$ (D) $\frac{nRT}{g} \left[\frac{l_1 - l_2}{l_1 l_2} \right]$

12. Two satellites, A and B, have masses m and $2m$ respectively. A is in a circular orbit of radius R , and B is in a circular orbit of radius $2R$ around the earth. The ratio of their kinetic energies, T_A/T_B , is :

(A) $\frac{1}{2}$ (B) 1
 (C) 2 (D) $\sqrt{\frac{1}{2}}$

13. A long cylindrical vessel is half filled with a liquid. When the vessel is rotated about its own vertical axis, the liquid rises up near the wall. If the radius of vessel is 5 cm and its rotational speed is 2 rotations per second, then the difference in the heights between the centre and the sides, in cm, will be :

(A) 2.0 (B) 0.1
 (C) 0.4 (D) 1.2

14. A block kept on a rough inclined plane, as shown in the figure, remains at rest upto a maximum force 2 N down the inclined plane. The maximum external force up the inclined plane that does not move the block is 10 N. The coefficient of static friction between the block and the plane is :

[Take $g = 10 \text{ m/s}^2$]

(A) $\frac{\sqrt{3}}{2}$ (B) $\frac{\sqrt{3}}{4}$
 (C) $\frac{1}{2}$ (D) $\frac{2}{3}$

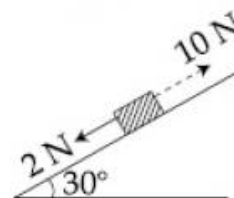

15. In a Frank-hertz experiment, an electron of energy 5.6 eV passes through mercury vapour and emerges with an energy 0.7 eV. The minimum wavelength of photons emitted by mercury atoms is close to :

(A) 1700 nm (B) 2020 nm
 (C) 220 nm (D) 250 nm

16. A particle of mass 20 g is released with an initial velocity 5 m/s along the curve from the point A, as shown in the figure. The point A is at height h from point B. The particle slides along the frictionless surface. When the particle reaches point B, its angular momentum about O will be :

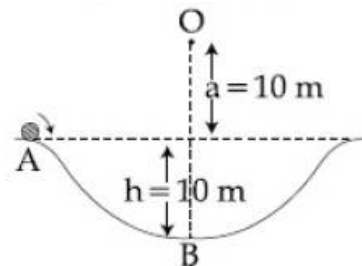

[Take $g = 10 \text{ m/s}^2$]

- (A) $2 \text{ kg-m}^2/\text{s}$ (B) $8 \text{ kg-m}^2/\text{s}$
 (C) $6 \text{ kg-m}^2/\text{s}$ (D) $3 \text{ kg-m}^2/\text{s}$

17. A galvanometer, whose resistance is 50 ohm, has 25 divisions in it. When a current of $4 \times 10^{-4} \text{ A}$ passes through it, its needle (pointer) deflects by one division. To use this galvanometer as a voltmeter of range 2.5 V, it should be connected to a resistance of :

- (A) 250 ohm (B) 200 ohm
 (C) 6200 ohm (D) 6250 ohm

18. A soap bubble, blown by a mechanical pump at the mouth of a tube, increases in volume, with time, at a constant rate. The graph that correctly depicts the time dependence of pressure inside the bubble is given by :

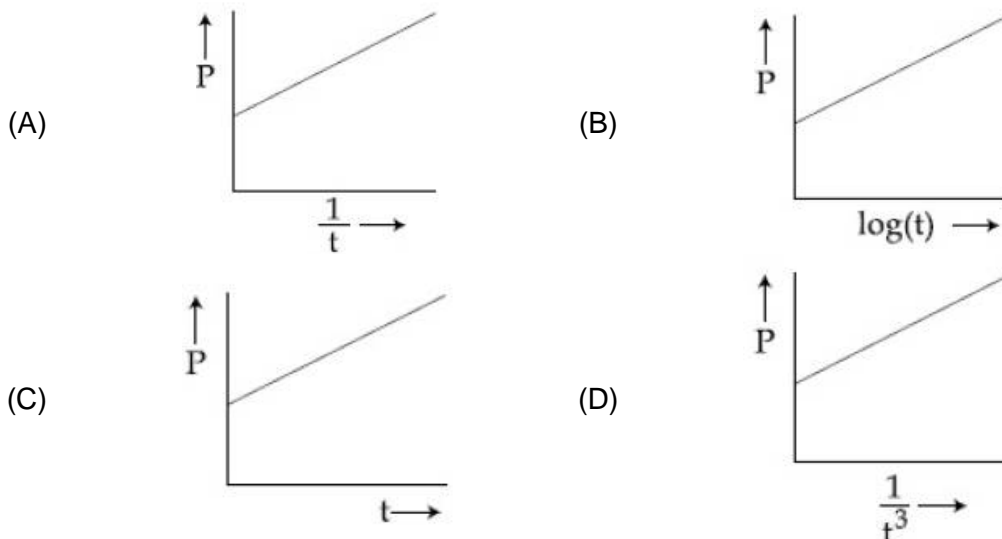

19. In the given circuit diagram, the currents, $I_1 = -0.3 \text{ A}$, $I_4 = 0.8 \text{ A}$ and $I_5 = 0.4 \text{ A}$, are flowing as shown. The currents I_2 , I_3 and I_6 , respectively are :

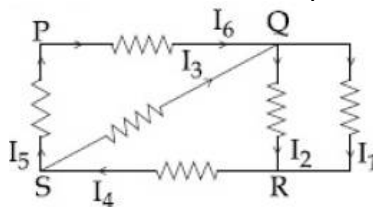

- (A) 1.1 A, -0.4 A , 0.4 A (B) 1.1 A, 0.4 A , 0.4 A
 (C) 0.4 A , 1.1 A, 0.4 A (D) -0.4 A , 0.4 A , 1.1 A

JEE-MAIN-2019 (12th Jan-Second Shift)-PCM-6

20. A resonance tube is old and has jagged end. It is still used in the laboratory to determine velocity of sound in air. A tuning fork of frequency 512 Hz produces first resonance when the tube is filled with water to a mark 11 cm below a reference mark, near the open end of the tube. The experiment is repeated with another fork of frequency 256 Hz which produces first resonance when water reaches a mark 27 cm below the reference mark. The velocity of sound in air, obtained in the experiment, is close to :
- (A) 322 ms^{-1} (B) 341 ms^{-1}
 (C) 335 ms^{-1} (D) 328 ms^{-1}
21. A paramagnetic material has 10^{28} atoms/ m^3 . Its magnetic susceptibility at temperature 350 K is 2.8×10^{-4} . Its susceptibility at 300 K is :
- (A) 3.267×10^{-4} (B) 3.672×10^{-4}
 (C) 3.726×10^{-4} (D) 2.672×10^{-4}
22. In a radioactive decay chain, the initial nucleus is ${}_{90}^{232}\text{Th}$. At the end there are 6 α -particles and 4 β -particles with are emitted. If the end nucleus is ${}^A_Z\text{X}$, A and Z are given by :
- (A) $A = 208; Z = 80$ (B) $A = 202; Z = 80$
 (C) $A = 208; Z = 82$ (D) $A = 200; Z = 81$
23. Let l , r , c and v represent inductance, resistance, capacitance and voltage, respectively. The dimension of $\frac{1}{rcv}$ in SI units will be :
- (A) $[\text{LA}^{-2}]$ (B) $[\text{A}^{-1}]$
 (C) $[\text{LTA}]$ (D) $[\text{LT}^2]$
24. Formation of real image using a biconvex lens is shown below :

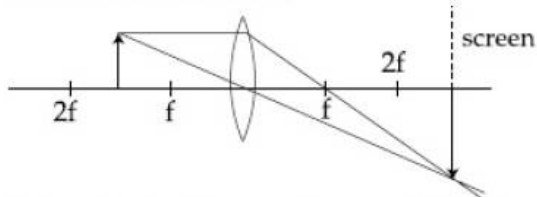

- If the whole set up is immersed in water without disturbing the object and the screen positions, what will one observe on the screen?
- (A) Image disappears (B) Magnified image
 (C) Erect real image (D) No change
25. When a certain photosensitive surface is illuminated with monochromatic light of frequency ν , the stopping potential for the photo current is $-V_0/2$. When the surface is illuminated by monochromatic light of frequency $\nu/2$, the stopping potential is $-V_0$. The threshold frequency for photoelectric emission is :
- (A) $\frac{5\nu}{3}$ (B) $\frac{4}{3}\nu$
 (C) 2ν (D) $\frac{3\nu}{2}$

26. A simple harmonic motion is represented by :

$$y = 5(\sin 3\pi t + \sqrt{3} \cos 3\pi t) \text{ cm}$$

The amplitude and time period of the motion are :

- (A) 10 cm, $\frac{2}{3}$ s
 (B) 10 cm, $\frac{3}{2}$ s
 (C) 5 cm, $\frac{3}{2}$ s
 (D) 5 cm, $\frac{2}{3}$ s

27. Two particles A, B are moving on two concentric circles of radii R_1 and R_2 with equal angular speed ω . At $t = 0$, their positions and direction of motion are shown in the figure :

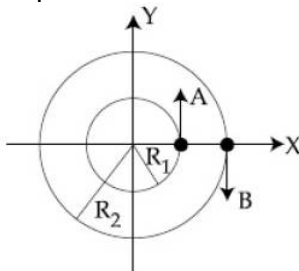

The relative velocity $\vec{v}_A - \vec{v}_B$ at $t = \frac{\pi}{2\omega}$ is given by :

- (A) $\omega(R_1 + R_2)\hat{i}$
 (B) $-\omega(R_1 + R_2)\hat{i}$
 (C) $\omega(R_2 - R_1)\hat{i}$
 (D) $\omega(R_1 - R_2)\hat{i}$
28. The mean intensity of radiation on the surface of the Sun is about 10^8 W/m^2 . The rms value of the corresponding magnetic field is closet to :
 (A) 1 T
 (B) 10^2 T
 (C) 10^{-2} T
 (D) 10^{-4} T
29. A parallel plate capacitor with plates of area 1 m^2 each, are at a separation of 0.1 m. If the electric field between the plates is 100 N/C, the magnitude of charge on each plate is:
 (A) $7.85 \times 10^{-10} \text{ C}$
 (B) $6.85 \times 10^{-10} \text{ C}$
 (C) $8.85 \times 10^{-10} \text{ C}$
 (D) $9.85 \times 10^{-10} \text{ C}$
30. The charge on a capacitor plate in a circuit, as a function of time, is shown in the figure :

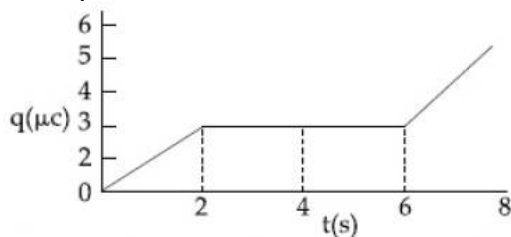

What is the value of current at $t = 4 \text{ s}$?

- (A) zero
 (B) $3 \mu\text{A}$
 (C) $2 \mu\text{A}$
 (D) $1.5 \mu\text{A}$

PART -B (CHEMISTRY)

31. 8 g of NaOH is dissolved in 18 g of H₂O. Mole fraction of NaOH in solution and molality (in mol kg⁻¹) of the solution respectively are :
 (A) 0.2, 22.20 (B) 0.2, 11.11
 (C) 0.167, 11.11 (D) 0.167, 22.20
32. The magnetic moment of an octahedral homoleptic Mn(II) complex is 5.9 BM. The suitable ligand for this complex is :
 (A) ethylenediamine (B) CN⁻
 (C) NCS⁻ (D) CO
33. The element that does NOT show catenation is :
 (A) Ge (B) Si
 (C) Sn (D) Pb
34. Among the following, the false statement is :
 (A) It is possible to cause artificial rain by throwing electrified sand carrying charge opposite to the one on clouds from an aeroplane.
 (B) Tyndall effect can be used to distinguish between a colloidal solution and a true solution.
 (C) Lyophilic sol can be coagulated by adding an electrolyte.
 (D) Latex is a colloidal solution of rubber particles which are positively charged.
35. The correct structure of histidine in a strongly acidic solution (pH = 2) is :

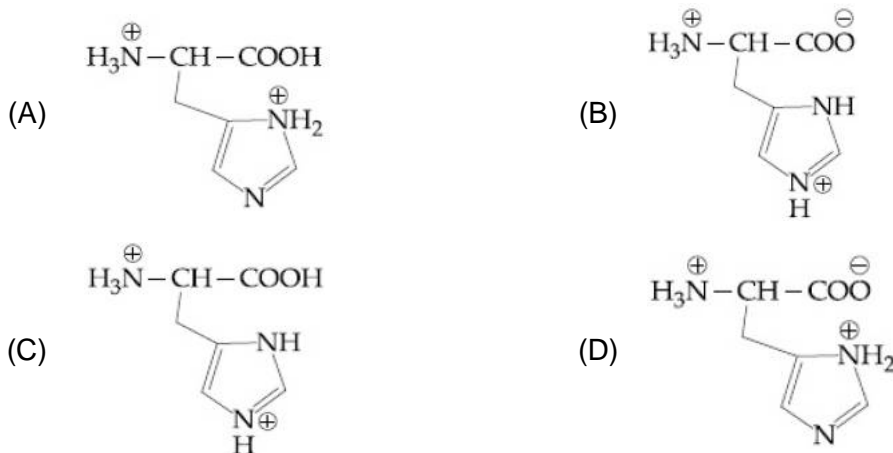

36. The major product of the following reaction is:

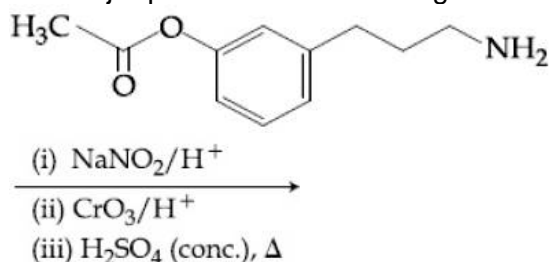

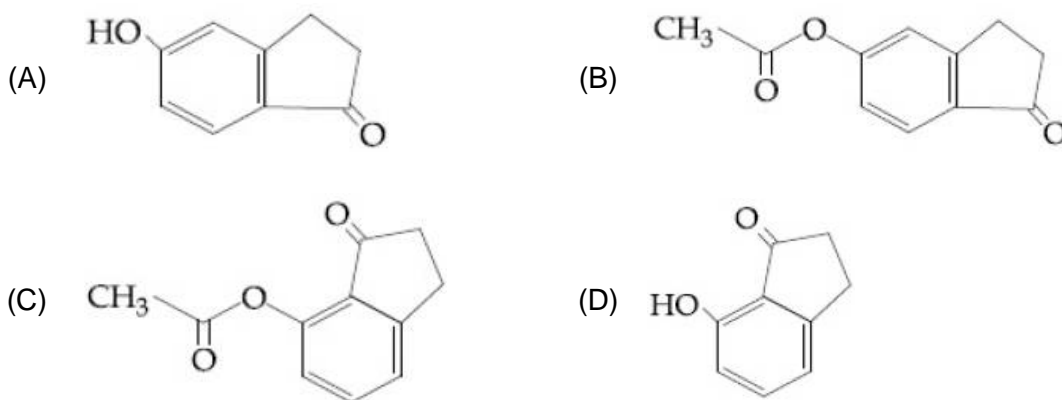

37. Λ_m° for NaCl, HCl and NaA are 126.4, 425.9 and 100.5 S cm²mol⁻¹, respectively. If the conductivity of 0.001 M HA is 5 × 10⁻⁵ S cm⁻¹, degree of dissociation of HA is :
- (A) 0.50 (B) 0.25
(C) 0.125 (D) 0.75
38. Molecules of benzoic acid (C₆H₅COOH) dimerise in benzene. 'w' g of the acid dissolved in 30 g of benzene shows a depression in freezing point equal to 2 K. If the percentage association of the acid to form dimer in the solution is 80, then w is :
(Given that K_f = 5 K kg mol⁻¹, Molar mass of benzoic acid = 122 g mol⁻¹)
- (A) 2.4 g (B) 1.0 g
(C) 1.5 g (D) 1.8 g
39. Chlorine on reaction with hot and concentrated sodium hydroxide gives :
- (A) Cl⁻ and ClO₃⁻ (B) Cl⁻ and ClO⁻
(C) ClO₃⁻ and ClO₂⁻ (D) Cl⁻ and ClO₂⁻
40. The major product of the following reaction is :

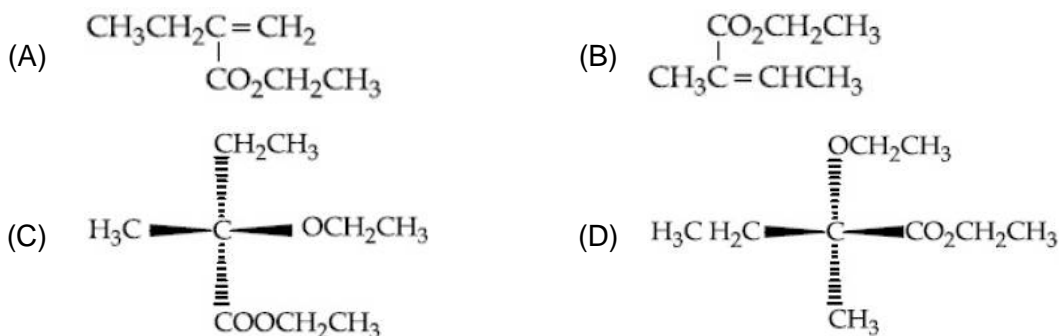
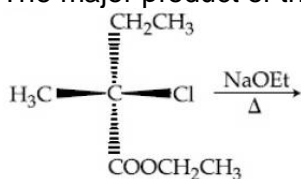

44. The correct order of atomic radii is :
 (A) Nd > Ce > Eu > Ho (B) Ho > Nd > Eu > Ce
 (C) Ce > Eu > Ho > Nd (D) Eu > Ce > Nd > Ho
45. The element that shows greater ability to form $p\pi - p\pi$ multiple bonds, is:
 (A) Sn (B) C
 (C) Ge (D) Si
46. The two monomers for the synthesis of Nylon 6, 6 are :
 (A) $\text{HOOC}(\text{CH}_2)_4\text{COOH}$, $\text{H}_2\text{N}(\text{CH}_2)_6\text{NH}_2$ (B) $\text{HOOC}(\text{CH}_2)_6\text{COOH}$, $\text{H}_2\text{N}(\text{CH}_2)_6\text{NH}_2$
 (C) $\text{HOOC}(\text{CH}_2)_4\text{COOH}$, $\text{H}_2\text{N}(\text{CH}_2)_4\text{NH}_2$ (D) $\text{HOOC}(\text{CH}_2)_6\text{COOH}$, $\text{H}_2\text{N}(\text{CH}_2)_4\text{NH}_2$
47. The aldehydes which will not form Grignard product with one equivalent Grignard reagents are:

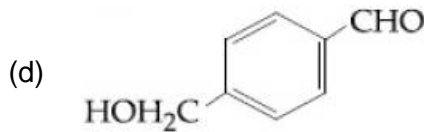
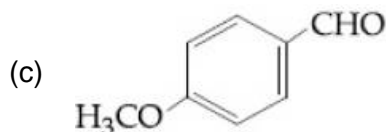
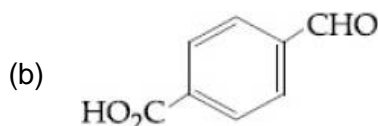
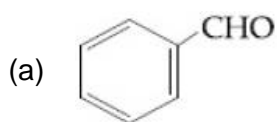

- (A) (b), (d) (B) (b), (c)
 (C) (b), (c), (d) (D) (c), (d)
48. Given :
 (i) $\text{C}(\text{graphite}) + \text{O}_2(\text{g}) \rightarrow \text{CO}_2(\text{g}); \Delta_r H^\circ = x \text{ kJ mol}^{-1}$
 (ii) $\text{C}(\text{graphite}) + \frac{1}{2}\text{O}_2(\text{g}) \rightarrow \text{CO}(\text{g}); \Delta_r H^\circ = y \text{ kJ mol}^{-1}$
 (iii) $\text{CO}(\text{g}) + \frac{1}{2}\text{O}_2(\text{g}) \rightarrow \text{CO}_2(\text{g}); \Delta_r H^\circ = z \text{ kJ mol}^{-1}$
 Based on the above thermochemical equations, find out which one of the following algebraic relationships is correct?
 (A) $x = y + z$ (B) $z = x + y$
 (C) $y = 2z - x$ (D) $x = y - z$
49. The volume strength of 1M H_2O_2 is : (Molar mass of $\text{H}_2\text{O}_2 = 34 \text{ g mol}^{-1}$)
 (A) 5.6 (B) 16.8
 (C) 11.35 (D) 22.4
50. The correct statement(s) among I to III with respect to potassium ions that are abundant within the cell fluids is/are :
 I. They activate many enzymes
 II. They participate in the oxidation of glucose to produce ATP
 III. Along with sodium ions, they are responsible for the transmission of nerve signals
 (A) I and II only (B) I and III only
 (C) I, II and III (D) III only

JEE-MAIN-2019 (12th Jan-Second Shift)-PCM-12

51. The compound that is NOT a common component of photochemical smog is :

- (A) O_3 (B) $H_3C-C(=O)-OONO_2$
 (C) $CH_2 = CHCHO$ (D) CF_2Cl_2

52. For a certain reaction consider the plot of $\ln k$ versus $1/T$ given in the figure. If the rate constant of this reaction at 400 K is $10^{-5} s^{-1}$, then the rate constant at 500 K is:

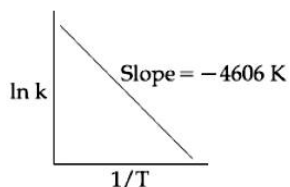

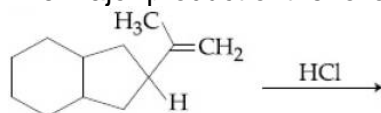

- (A) $10^{-6} s^{-1}$ (B) $2 \times 10^{-4} s^{-1}$
 (C) $10^{-4} s^{-1}$ (D) $4 \times 10^{-4} s^{-1}$
53. An open vessel at $27^\circ C$ is heated until two fifth of the air (assumed as an ideal gas) in it has escaped from the vessel. Assuming that the volume of the vessel remains constant, the temperature at which the vessel has been heated is :
- (A) $500^\circ C$ (B) 500 K
 (C) $750^\circ C$ (D) 750 K
54. The major product of the following reaction is :

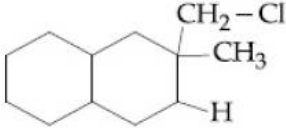
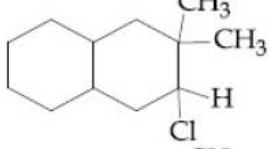
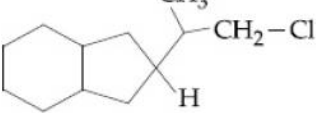
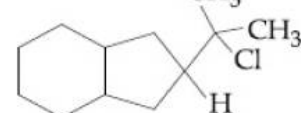

- (A)  (B) 
 (C)  (D) 

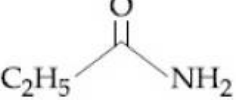
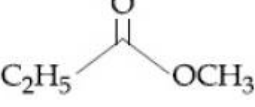
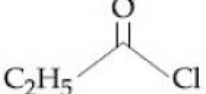
55. The increasing order of the reactivity of the following with $LiAlH_4$ is :

- (a)  (b) 
 (c)  (d) 

- (A) (b) < (a) < (c) < (d) (B) (b) < (a) < (d) < (c)
 (C) (a) < (b) < (d) < (c) (D) (a) < (b) < (c) < (d)

56. The pair that does NOT require calcination is :
 (A) ZnO and MgO (B) ZnO and Fe₂O₃·xH₂O
 (C) ZnCO₃ and CaO (D) Fe₂O₃ and CaCO₃·MgCO₃
57. The major product of the following reaction is :

$$\text{CH}_3\text{CH}_2\underset{\text{Br}}{\text{CH}}-\underset{\text{Br}}{\text{CH}_2} \xrightarrow[\text{in liq NH}_3]{\begin{array}{l} \text{(i) KOH alc.} \\ \text{(ii) NaNH}_2 \end{array}}$$
- (A) CH₃CH = C = CH₂ (B) $\text{CH}_3\text{CH}_2\underset{\text{NH}_2}{\text{CH}}-\underset{\text{NH}_2}{\text{CH}_2}$
 (C) CH₃CH = CHCH₂NH₂ (D) CH₃CH₂C ≡ CH
58. If K_{sp} of Ag₂CO₃ is 8 × 10⁻¹², the molar solubility of Ag₂CO₃ in 0.1 M AgNO₃ is :
 (A) 8 × 10⁻¹² M (B) 8 × 10⁻¹¹ M
 (C) 8 × 10⁻¹⁰ M (D) 8 × 10⁻¹³ M
59. The upper stratosphere consisting of the ozone layer protects us from the sun's radiation that falls in the wavelength region of :
 (A) 200 – 315 nm (B) 400 – 550 nm
 (C) 0.8 – 1.5 nm (D) 600 – 750 nm
60. If the de Broglie wavelength of the electron in nth Bohr orbit in a hydrogenic atom is equal to 1.5πa₀ (a₀ is Bohr radius), then the value of n/z is :
 (A) 0.40 (B) 1.50
 (C) 1.0 (D) 0.75

PART-C (MATHEMATICS)

61. $\lim_{x \rightarrow 1^-} \frac{\sqrt{\pi} - \sqrt{2 \sin^{-1} x}}{\sqrt{1-x}}$ is equal to :
- (A) $\frac{1}{\sqrt{2\pi}}$ (B) $\sqrt{\frac{2}{\pi}}$
 (C) $\sqrt{\frac{\pi}{2}}$ (D) $\sqrt{\pi}$
62. Let f be a differentiable function such that $f(1) = 2$ and $f'(x) = f(x)$ for all $x \in \mathbb{R}$. If $h(x) = f(f(x))$, then $h'(1)$ is equal to :
- (A) $2e^2$ (B) $4e$
 (C) $2e$ (D) $4e^2$
63. The integral $\int_1^e \left\{ \left(\frac{x}{e} \right)^{2x} - \left(\frac{e}{x} \right)^x \right\} \log_e x \, dx$ is equal to :
- (A) $\frac{1}{2} - e - \frac{1}{e^2}$ (B) $-\frac{1}{2} + \frac{1}{e} - \frac{1}{2e^2}$
 (C) $\frac{3}{2} - \frac{1}{e} - \frac{1}{2e^2}$ (D) $\frac{3}{2} - e - \frac{1}{2e^2}$
64. Let \vec{a} , \vec{b} , and \vec{c} be three unit vectors, out of which vectors \vec{b} and \vec{c} are non-parallel. If α and β are the angles which vector \vec{a} makes with vectors \vec{b} and \vec{c} respectively and $\vec{a} \times (\vec{b} \times \vec{c}) = \frac{1}{2} \vec{b}$, then $|\alpha - \beta|$ is equal to :
- (A) 30° (B) 90°
 (C) 60° (D) 45°
65. The integral $\int \frac{3x^{13} + 2x^{11}}{(2x^4 + 3x^2 + 1)^4} dx$ is equal to (where C is a constant of integration)
- (A) $\frac{x^4}{6(2x^4 + 3x^2 + 1)^3} + C$ (B) $\frac{x^{12}}{6(2x^4 + 3x^2 + 1)^3} + C$
 (C) $\frac{x^4}{(2x^4 + 3x^2 + 1)^3} + C$ (D) $\frac{x^{12}}{(2x^4 + 3x^2 + 1)^3} + C$
66. If $\sin^4 \alpha + 4 \cos^4 \beta + 2 = 4\sqrt{2} \sin \alpha \cos \beta$; $\alpha, \beta \in [0, \pi]$, then $\cos(\alpha + \beta)$ is equal to :
- (A) 0 (B) -1
 (C) $\sqrt{2}$ (D) $-\sqrt{2}$

67. If a curve passes through the point $(1, -2)$ and has slope of the tangent at any point (x, y) on it as $\frac{x^2 - 2y}{x}$, then the curve also passes through the point :
- (A) $(3, 0)$ (B) $(\sqrt{3}, 0)$
 (C) $(-1, 2)$ (D) $(-\sqrt{2}, 1)$
68. If an angle between the line, $\frac{x+1}{2} = \frac{y-2}{1} = \frac{z-3}{-2}$ and the plane, $x - 2y - kz = 3$ is $\cos^{-1}\left(\frac{2\sqrt{2}}{3}\right)$, then a value of k is :
- (A) $\sqrt{\frac{5}{3}}$ (B) $\sqrt{\frac{3}{5}}$
 (C) $-\frac{3}{5}$ (D) $-\frac{5}{3}$
69. $\lim_{x \rightarrow \infty} \left(\frac{n}{n^2 + 1^2} + \frac{n}{n^2 + 2^2} + \frac{n}{n^2 + 3^2} + \dots + \frac{1}{5n} \right)$ is equal to
- (A) $\frac{\pi}{4}$ (B) $\tan^{-1}(3)$
 (C) $\frac{\pi}{2}$ (D) $\tan^{-1}(2)$
70. In a game, a man wins Rs. 100 if he gets 5 or 6 on a throw of a fair die and loses Rs. 50 for getting any other number on the die. If he decides to throw the die either till he gets a five or a six or to a maximum of three throws, then his expected gain/loss (in rupees) is :
- (A) $\frac{400}{9}$ loss (B) 0
 (C) $\frac{400}{3}$ gain (D) $\frac{400}{3}$ loss
71. If a straight line passing through the point $P(-3, 4)$ is such that its intercepted portion between the coordinate axes is bisected at P , then its equation is :
- (A) $3x - 4y + 25 = 0$ (B) $4x - 3y + 24 = 0$
 (C) $x - y + 7 = 0$ (D) $4x + 3y = 0$
72. There are m men and two women participating in a chess tournament. Each participant plays two games with every other participant. If the number of games played by the men between themselves exceeds the number of games played between the men and the women by 84, then the value of m is :
- (A) 12 (B) 11
 (C) 9 (D) 7

JEE-MAIN-2019 (12th Jan-Second Shift)-PCM-16

73. The tangent to the curve $y = x^2 - 5x + 5$, parallel to the line $2y = 4x + 1$, also passes through the point :
- (A) $\left(\frac{7}{2}, \frac{1}{4}\right)$ (B) $\left(\frac{1}{8}, -7\right)$
(C) $\left(-\frac{1}{8}, 7\right)$ (D) $\left(\frac{1}{4}, \frac{7}{2}\right)$
74. Let S be the set of all real values of λ such that a plane passing through the points $(-\lambda^2, 1, 1)$, $(1, -\lambda^2, 1)$ and $(1, 1, -\lambda^2)$ also passes through the point $(-1, -1, 1)$. Then S is equal to:
- (A) $\{\sqrt{3}\}$ (B) $\{\sqrt{3}, -\sqrt{3}\}$
(C) $\{1, -1\}$ (D) $\{3, -3\}$
75. Let z_1 and z_2 be two complex numbers satisfying $|z_1| = 9$ and $|z_2 - 3 - 4i| = 4$. Then the minimum value of $|z_1 - z_2|$ is :
- (A) 0 (B) $\sqrt{2}$
(C) 1 (D) 2
76. The total number of irrational terms in the binomial expansion of $\left(7^{\frac{1}{5}} - 3^{\frac{1}{10}}\right)^{60}$ is :
- (A) 55 (B) 49
(C) 48 (D) 54
77. The equation of a tangent to the parabola, $x^2 = 8y$, which makes an angle θ with the positive direction of x-axis, is :
- (A) $y = x \tan \theta + 2 \cot \theta$ (B) $y = x \tan \theta - 2 \cot \theta$
(C) $x = y \cot \theta + 2 \tan \theta$ (D) $x = y \cot \theta - 2 \tan \theta$
78. In a class of 60 students, 40 opted for NCC, 30 opted for NSS and 20 opted for both NCC and NSS. If one of these students is selected at random, then the probability that the student selected has opted neither for NCC nor for NSS is :
- (A) $\frac{1}{6}$ (B) $\frac{1}{3}$
(C) $\frac{2}{3}$ (D) $\frac{5}{6}$
79. The mean and the variance of five observations are 4 and 5.20, respectively. If three of the observations are 3, 4 and 4; then the absolute value of the difference of the other two observations, is :
- (A) 7 (B) 5
(C) 1 (D) 3

80. If $A = \begin{bmatrix} 1 & \sin \theta & 1 \\ -\sin \theta & 1 & \sin \theta \\ -1 & -\sin \theta & 1 \end{bmatrix}$; then for all $\theta \in \left(\frac{3\pi}{4}, \frac{5\pi}{4}\right)$, $\det(A)$ lies in the interval :
- (A) $\left(1, \frac{5}{2}\right]$ (B) $\left[\frac{5}{2}, 4\right)$
 (C) $\left(0, \frac{3}{2}\right]$ (D) $\left(\frac{3}{2}, 3\right]$
81. If a circle of radius R passes through the origin O and intersects the coordinate axes at A and B, then the locus of the foot of perpendicular from O on AB is :
- (A) $(x^2 + y^2)^2 = 4R^2x^2y^2$ (B) $(x^2 + y^2)^3 = 4R^2x^2y^2$
 (C) $(x^2 + y^2)^2 = 4Rx^2y^2$ (D) $(x^2 + y^2)(x + y) = R^2xy$
82. The set of all values of λ for which the system of linear equations
 $x - 2y - 2z = \lambda x$
 $x + 2y + z = \lambda y$
 $-x - y = \lambda z$
- (A) is a singleton (B) contains exactly two elements
 (C) is an empty set (D) contains more than two elements
83. If the function f given by $f(x) = x^3 - 3(a - 2)x^2 + 3ax + 7$, for some $a \in \mathbb{R}$ is increasing in $(0, 1]$ and decreasing in $[1, 5)$, then a root of the equation, $\frac{f(x) - 14}{(x - 1)^2} = 0$ ($x \neq 1$) is :
- (A) -7 (B) 5
 (C) 7 (D) 6
84. Let Z be the set of integers. If $A = \{x \in \mathbb{Z} : 2^{(x+2)(x^2-5x+6)} = 1\}$ and $B = \{x \in \mathbb{Z} : -3 < 2x - 1 < 9\}$, then the number of subsets of the set $A \times B$, is :
- (A) 2^{15} (B) 2^{18}
 (C) 2^{12} (D) 2^{10}
85. If ${}^nC_4, {}^nC_5$ and nC_6 are in A.P., then n can be :
- (A) 9 (B) 14
 (C) 11 (D) 12
86. Let S and S' be the foci of an ellipse and B be any one of the extremities of its minor axis. If $\Delta S'BS$ is a right angled triangle with right angle at B and area $(\Delta S'BS) = 8$ sq. units, then the length of a latus rectum of the ellipse is :
- (A) 4 (B) $2\sqrt{2}$
 (C) $4\sqrt{2}$ (D) 2

JEE-MAIN-2019 (12th Jan-Second Shift)-PCM-18

87. If the angle of elevation of a cloud from a point P which is 25 m above a lake be 30° and the angle of depression of reflection of the cloud in the lake from P be 60° , then the height of the cloud (in meters) from the surface of the lake is :
(A) 60 (B) 50
(C) 45 (D) 42
88. The expression $\sim(\sim p \rightarrow q)$ is logically equivalent to :
(A) $\sim p \wedge \sim q$ (B) $p \wedge \sim q$
(C) $\sim p \wedge q$ (D) $p \wedge q$
89. If the sum of the first 15 terms of the series $\left(\frac{3}{4}\right)^3 + \left(1\frac{1}{2}\right)^3 + \left(2\frac{1}{4}\right)^3 + 3^3 + \left(3\frac{3}{4}\right)^3 + \dots$ is equal to 225 k, then k is equal to :
(A) 108 (B) 27
(C) 54 (D) 9
90. The number of integral values of m for which the quadratic expression, $(1 + 2m)x^2 - 2(1 + 3m)x + 4(1 + m)$, $x \in \mathbb{R}$, is always positive, is :
(A) 3 (B) 8
(C) 7 (D) 6

JEE (Main) – 2019

ANSWERS

PART A – PHYSICS

1. D	2. A	3. No option is correct	
4. B	5. A	6. A	7. D
8. B	9. C	10. B	11. D
12. B	13. A	14. A	15. D
16. C	17. B	18. No option is correct	
19. B	20. D	21. A	22. C
23. B	24. A	25. D	26. A
27. C	28. D	29. C	30. A

PART B – CHEMISTRY

31. C	32. C	33. D	34. C
35. C	36. A	37. C	38. A
39. A	40. B	41. A	42. B
43. B	44. D	45. B	46. A
47. A	48. A	49. C	50. D
51. A	52. C	53. C	54. D
55. C	56. A	57. D	58. C
59. A	60. D		

PART C – MATHEMATICS

61. B	62. B	63. D	64. A
65. B	66. D	67. B	68. A
69. D	70. B	71. B	72. A
73. B	74. B	75. A	76. D
77. C	78. A	79. A	80. D
81. B	82. A	83. C	84. A
85. B	86. A	87. B	88. A
89. B	90. C		

HINTS AND SOLUTIONS

PART A – PHYSICS

1. $I = I_{CM} + Mx^2$

$$I_{CM} = \frac{2}{5}MR^2$$

$$I = \frac{2}{5}MR^2 + Mx^2$$

2. In first case:

$$\frac{\frac{mg}{A}}{\left(\frac{\Delta l_1}{l}\right)} = Y \quad \Rightarrow \quad \Delta l_1 = \frac{mg}{\left(\frac{YA}{l}\right)}$$

In second case:

$$\frac{\frac{mg - B}{A}}{\left(\frac{\Delta l_1}{l}\right)} = Y \quad \Rightarrow \quad \Delta l_2 = \frac{mg - B}{\left(\frac{YA}{l}\right)} = \frac{\left(\frac{3mg}{4}\right)}{\left(\frac{YA}{l}\right)}$$

$$\Rightarrow \quad \Delta l_2 = \frac{3}{4}\Delta l_1 = 3 \text{ mm}$$

3. For the first branch:

$$\tan \phi_1 = \frac{-X_C}{R_2} = \frac{1}{\left(\frac{100 \times \frac{\sqrt{3}}{2} \times 10^{-6}}{20}\right)} \approx -10^{+3}$$

$$\Rightarrow \quad \phi_1 \approx -90^\circ.$$

For the second branch:

$$\tan \phi_2 = \frac{X_L}{R} = \sqrt{3}$$

$$\Rightarrow \quad \phi_2 \approx 60^\circ.$$

Phase difference between current in branch 1 and 2 = 150° .

No option is correct.

4. The mean time between two collision $\propto \frac{P}{\sqrt{T}}$

$$\frac{\Delta t_1}{\Delta t_2} = \frac{P_1}{P_2} \times \frac{\sqrt{T_2}}{\sqrt{T_1}}$$

$$\Rightarrow \quad \frac{6 \times 10^{-8}}{\Delta t_2} = \left(\frac{\sqrt{3}}{\sqrt{5}}\right) \times 2$$

$$\Rightarrow \quad \Delta t_2 = 6 \times 10^{-8} \times \frac{1}{2} \sqrt{\frac{5}{3}} \approx 4 \times 10^{-8} \text{ sec.}$$

5. When switched on:

$$V_{CE} = 0$$

$$V_{CC} - R_C i_C = 0$$

$$i_C = \frac{V_{CC}}{R_C} = 5 \times 10^{-3} \text{ A}$$

$$I_C = \beta i_B$$

$$\Rightarrow i_B = 25 \mu\text{A}$$

$$\Rightarrow V_{BB} = i_B R_B - V_{BE} = 0$$

$$\Rightarrow V_{BB} = V_{BE} + i_B R_B = 3.5 \text{ V}$$

$$6. C_{eq} = 0.5 \mu\text{F} = \frac{\left(1 + \frac{4}{3}\right)C}{\frac{7}{3} + C} = \frac{7C}{\frac{7}{3} + C} = \frac{1}{2}$$

$$\Rightarrow \frac{14C}{3} = C + \frac{7}{3}$$

$$C = \frac{7}{11}$$

7.

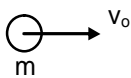

$$(I) \quad mv_0 = -mv_1 + mv_2$$

$$(II) \quad v_0 = v_1 + v_2$$

$$\frac{2mv_0}{m+M} = v_2$$

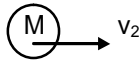
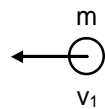

$$KE_f = \frac{1}{2}mv_1^2 = \frac{1}{2}m\left(\frac{M-m}{M+m}\right)^2 v_0^2 = \frac{36}{100} \times \frac{1}{2}mv_0^2$$

$$\Rightarrow M = 4m.$$

8. $\therefore \text{Emf} = B\ell v \sin 45^\circ$

$$= (0.3 \times 10^{-4}) \times (10) \times 5 \times \frac{1}{\sqrt{2}}$$

$$= 1.1 \times 10^{-3} \text{ V}$$

9. Covering range of transition power = $\sqrt{2hR}$
To double the range make height 4 times.

10.

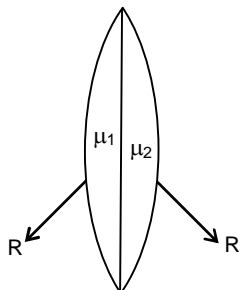

$$\frac{1}{f} = \frac{(\mu_1 - 1)}{R} + \frac{(1 - \mu_2)}{R}$$

$$\frac{1}{f} = \frac{(\mu_1 - \mu_2)}{R}$$

$$\Rightarrow f = \frac{R}{\mu_1 - \mu_2}$$

11.

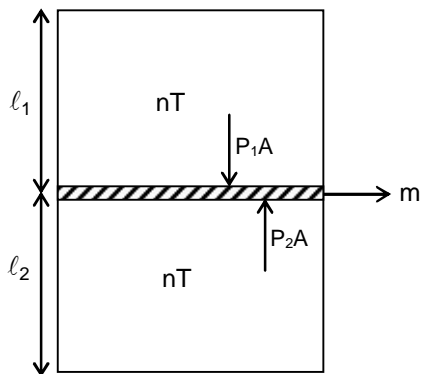

$$P_2A - P_1A = mg$$

$$m = \frac{1}{g} \left(\frac{P_1A l_1}{l_1} - \frac{P_2A l_2}{l_2} \right)$$

$$m = \frac{1}{g} \left(\frac{nRT}{l_1} - \frac{nRT}{l_2} \right)$$

$$m = \frac{nRT}{g} \left(\frac{1}{l_1} - \frac{1}{l_2} \right)$$

12. $KE_A = \frac{1}{2} m \left(\frac{GM}{R} \right)$

$$KE_B = \frac{1}{2} (2m) \left(\frac{GM}{2R} \right)$$

$$\Rightarrow \frac{KE_A}{KE_B} = 1$$

13. $y = \frac{w^2 x^2}{2g} = \frac{(2 \times 2\pi)^2 \times (0.05)^2}{2g}$
 $= 25 \times 8 \times 10^{-4}$
 $= 2 \text{ cm}$

14. $mg \sin \theta + 2 = \mu mg \cos \theta \quad \dots(1)$

$$10 - mg \sin \theta = \mu mg \cos \theta \quad \dots(2)$$

On adding: (1) + (2)

$$12 = 2\mu mg \frac{\sqrt{3}}{2} \quad ; \quad \mu mg = \frac{12}{\sqrt{3}}$$

On (1) - (2):

$$8 = 2mg \times \frac{1}{2} \quad ; \quad mg = 8 \quad ; \quad \mu = \frac{\sqrt{3}}{2}$$

15. $5.6 \text{ eV} - 0.7 \text{ eV} = 4.9 \text{ eV} = \frac{12410 \text{ eV} - A^\circ}{\lambda}$

$$\lambda = \frac{12410 \text{ eV} - A^\circ}{4.9 \text{ eV}}$$

$$\approx 250 \text{ nm}$$

16. $v = \sqrt{5^2 + 2gh} = \sqrt{5^2 + 2 \times 10 \times 10} = \sqrt{225}$
 $= 15 \text{ m/s}$

$$h = rmv = 20 \times (20 \times 10^{-3} \text{ kg}) \times (15)$$

$$= 6 \text{ kg m}^2/\text{sec}$$

17. $V_o = i_{g_0} (R_G + R)$
 $i_{g_0} = 4 \times 10^{-4} \times 25 = 10^{-2} \text{ A}$
 $V_o = 2.5 \text{ V}$
 $R_g + R = \frac{V_o}{i_{g_0}} = \frac{2.5}{10^{-2}} = 250$
 $\Rightarrow R = 200 \Omega.$

18. $V = kt = \frac{4}{3} \pi R^3$
 $R = \left(\frac{3k}{4\pi} t \right)^{1/3}$
 $P_{in} = P_{atm} + \frac{4T}{R}$
 \Rightarrow **Bonus**

19. $I_3 + I_5 = I_4 \Rightarrow I_3 = I_4 - I_5 = 0.4 \text{ A}$
 $I_1 + I_2 = I_4 \Rightarrow I_2 = I_4 - I_1 = 1.1 \text{ A}$
 $I_3 + I_6 = I_2 + I_1 \Rightarrow I_6 = I_2 + I_1 - I_3 = 0.4 \text{ A}$

20. $\lambda_1 = 4(11 + e) \frac{V}{512}$
 $\lambda_2 = 4(27 + e) \frac{V}{256}$
 $\frac{11 + e}{27 + e} = \frac{1}{2}$
 $\Rightarrow 22 + 2e = 27 + e$
 $\Rightarrow e = 5$

21. For paramagnetic materials $\chi \propto \frac{1}{R}$
 $\frac{\chi_1}{\chi_2} = \frac{T_2}{T_1}$
 $\Rightarrow \chi_2 = \frac{T_1}{T_2} \times \chi_1 = \frac{350}{300} \times 2.8 \times 10^{-4}$
 $= 3.267 \times 10^{-4}$

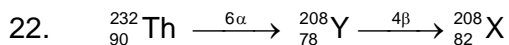

23. $\frac{L}{RCV} = [A^{-1}]$

24. If the water is filled focal length will decrease and image will disappear.

JEE-MAIN-2019 (12th Jan-Second Shift)-PCM-24

25. $eV_s = hv - \phi$
 $\left\{ \frac{-eV_o}{2} = hv - \phi \right\} \times 2 \quad \dots(1)$

$-eV_o = \frac{hv}{2} - \phi \quad \dots(2)$

$0 = 2hv - 2\phi - \frac{hv}{2} + \phi$

$\phi = \frac{3hv}{2} \Rightarrow v_{th} = \frac{3v}{2}$

26. $y = 5(\sin 3\pi t + \sqrt{3} \cos 3\pi t)$ cm

$\Rightarrow y = 10 \sin(3\pi t + \phi)$

$\Rightarrow A = 10$ cm

$\Rightarrow T = \frac{2}{3}$ sec

27.

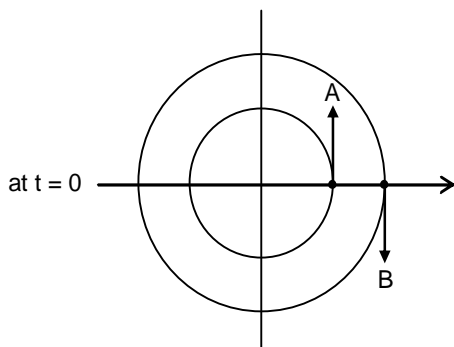

$\vec{v}_A - \vec{v}_B = -\omega R_1 \hat{i} + \omega \cdot R_2 \hat{i}$
 $= \omega(R_2 - R_1) \hat{i}$

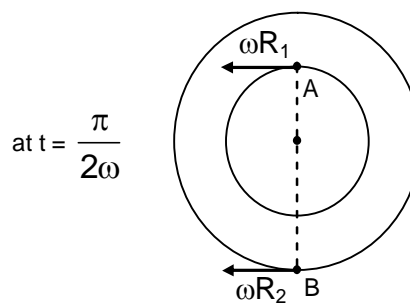

28. $I = \frac{B_o^2}{2\mu_o} \times C$

$B_o^2 = I \times 2\mu_o \times C$

$B_o^2 = \frac{10^3 \times 2 \times 4\pi \times 10^{-7}}{3 \times 10^8}$

$B_o \approx 10^{-4}$ T

29. $E = \frac{q}{A\epsilon_o}$

$\Rightarrow q = EA\epsilon_o$

$\Rightarrow q = 100 \times 1 \times 8.85 \times 10^{-12}$

$\Rightarrow q = 8.85 \times 10^{-10}$ C

30. Current = slope of $q - t$ graph = 0. [at $t = 4$ sec]

PART B – CHEMISTRY

31. Moles of NaOH = $\frac{8}{40} = 0.2$

Moles of H₂O = $\frac{18}{18} = 1$

Mole fraction of NaOH = $\frac{0.2}{1.2} = 0.167$

Molality = $\frac{8}{40} \times \frac{1000}{18} = 11.11$

32. Homoleptic complexes contain identical ligands, e.g., [Mn(NCS)₆]⁴⁻.

33. Due to the lowest bond energy of Pb – Pb bond.

34. Lyophobic sols are coagulated by adding electrolysis.

35. The COO⁻ group absorbs H⁺ in acidic medium (pH = 2)

36.

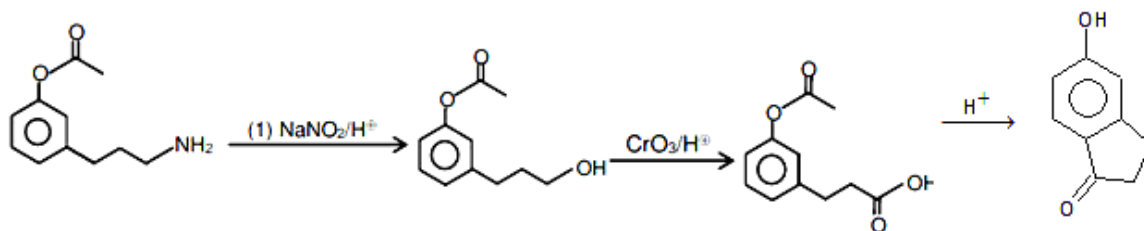

37. $\lambda_m^0(\text{HA}) = 100.5 + 425.9 - 126.4 = 400$

$\lambda_m^0 = \frac{K \times 1000}{M} = \frac{5 \times 10^{-5} \times 10^3}{10^{-3}} = 50$

$\alpha = \frac{50}{400} = 0.125$

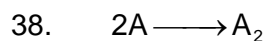

$1 - \alpha \quad \frac{\alpha}{2}$

$1 - 0.8 \quad \frac{0.8}{2}$

$i = 1 - 0.8 + \frac{0.8}{2} = 0.6$

$\Delta T_f = K_f \times i \times m = 5 \times 0.6 \times \frac{x}{122} \times \frac{1000}{30} = 2$ (Since $\Delta T_f = 2$)

$\therefore x = 2.44 \text{ g}$

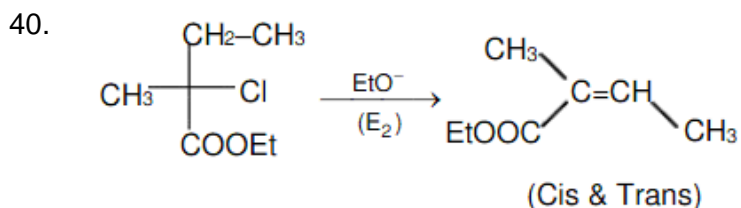
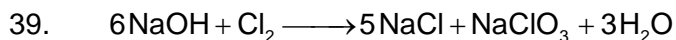

41. The plot (b) and (d) are incorrect. The correct ones are given below:

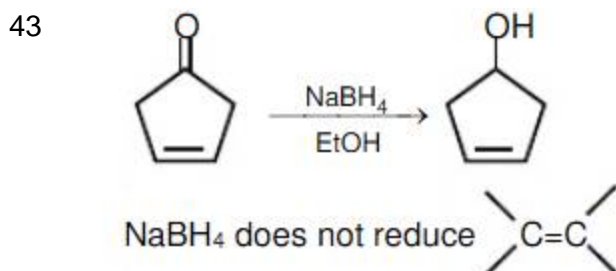
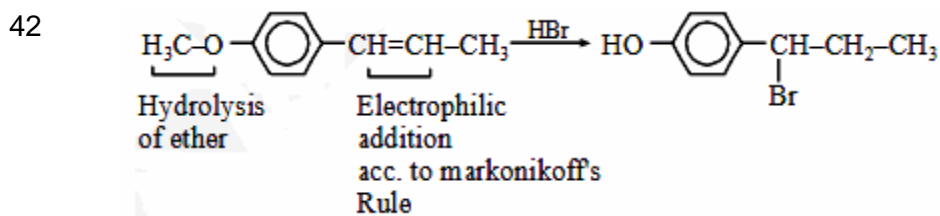
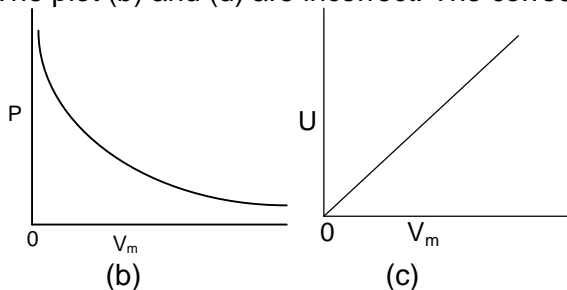

44. The atomic radii are

Eu = 199 pm

Ce = 183 pm

Nd = 181 pm

Ho = 176 pm

45. It is due to the smallest atomic size of carbon in the given options.

46. The monomers are hexamethylene diamine and adipic acid.

47. Each of (b) and (d) will react two moles of Grignard reagent.

48. (ii) + (iii) = (i)
Y + z = x

49. Volume strength = $11.35 \times M = 11.35$ (STP)
50. Active transport proteins exchanges Na^+ ions for K^+ ions across the plasma membrane of animal cells.
51. O_3 is not common component of London and Los Angeles smog. It is present only in Los Angeles smog

52.
$$\ln n = \ln A - \frac{E_a}{RT} = \ln A - \frac{4606}{T}$$

$$\ln \left(\frac{k}{10^{-5}} \right) = \left(\frac{E_a}{R} \right) \times \frac{500 - 400}{500 \times 400}$$

$$\ln \left(\frac{k}{10^{-5}} \right) = 4606 \times \frac{1}{2000} = 2.303 = \ln 10$$

$$\ln \left(\frac{k}{10^{-5}} \right) = \ln 10$$

$$k = 10^{-4}$$

53. $n_1 T_1 = n_2 T_2$
 $n \times 300 = \left(n - \frac{2n}{5} \right) T_2$
 $300 = \frac{3}{5} T_2 \Rightarrow T_2 = 500 \text{ K}$

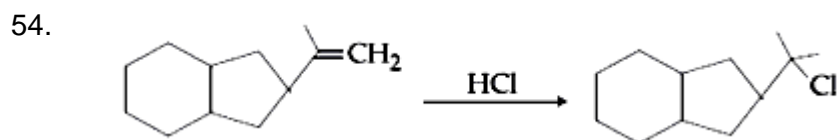

55. The order is identical to nucleophilic substitution order:
 Acid chloride > Acid anhydride > Acid > Amide

56. In calcination the ore is converted to metal oxide. ZnO and MgO are already in oxide form.

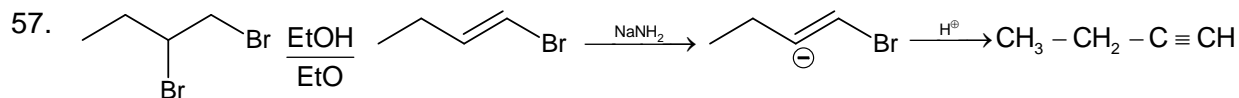

58. $8 \times 10^{-12} = (2S' + 0.1)^2 S'$
 or $S' = 8 \times 10^{-10} \text{ M}$

59. In ozone layer the wavelength of U.V radiation is 200 – 340 nm.

60. $2\pi r = n\lambda$
 $\lambda = \frac{2\pi r}{n} = \frac{2\pi n^2 a_0}{n \times Z} = 2\pi \frac{n}{Z} a_0$
 $\lambda = 1.5\pi a_0$
 $\therefore 2\pi \frac{n}{Z} a_0 = 1.5\pi a_0$
 $\therefore \frac{n}{Z} = \frac{1.5}{2} = 0.75$

PART C – MATHEMATICS

61. $\lim_{x \rightarrow 1} \frac{\sqrt{\pi} - \sqrt{2\sin^{-1} x}}{\sqrt{1-x}} \times \frac{\sqrt{\pi} + \sqrt{2\sin^{-1} x}}{\sqrt{\pi} + \sqrt{2\sin^{-1} x}}$
 $\lim_{x \rightarrow 1} \frac{2\left(\frac{\pi}{2} - \sin^{-1} x\right)}{\sqrt{1-x}\left(\sqrt{\pi} + \sqrt{2\sin^{-1} x}\right)}$
 $\lim_{x \rightarrow 1} \frac{2\cos^{-1} x}{\sqrt{1-x}} \cdot \frac{1}{2\sqrt{\pi}}$
 Assuming $x = \cos \theta$
 $\lim_{\theta \rightarrow 0^+} \frac{2\theta}{\sqrt{2}\sin\left(\frac{\theta}{2}\right)} \cdot \frac{1}{2\sqrt{\pi}} = \sqrt{\frac{2}{\pi}}$

62. $\frac{f'(x)}{f(x)} = 1 \quad \forall x \in \mathbb{R}$
 Integrate and use $f(1) = 2$
 $f(x) = 2e^{x-1} \Rightarrow f'(x) = 2e^{x-1}$
 $h(x) = f(f(x)) \Rightarrow h'(x) = f'(f(x))f'(x)$
 $h'(1) = f'(f(1))f'(1)$
 $= f'(2)f'(1)$
 $= 2e \cdot 2 = 4e$

63. $\int_1^e \left(\frac{x}{e}\right)^{2x} \log_e x \cdot dx - \int_1^e \left(\frac{e}{x}\right) \log_e x \cdot dx$
 Let $\left(\frac{x}{e}\right)^{2x} = t, \left(\frac{e}{x}\right)^x = v$
 $= \frac{1}{2} \int_{\left(\frac{1}{e}\right)^2}^1 dt + \int_e^1 dv = \frac{1}{2} \left(1 - \frac{1}{e^2}\right) + (1 - e) = \frac{3}{2} - \frac{1}{2e^2} - e$

64. $(\vec{a} \cdot \vec{c})\vec{b} - (\vec{a} \cdot \vec{b})\vec{c} = \frac{1}{2}\vec{b}$
 $\therefore \vec{b}$ and \vec{c} are linearly independent
 $\therefore \vec{a} \cdot \vec{c} = \frac{1}{2}$ and $\vec{a} \cdot \vec{b} = 0$
 (All given vectors are unit vectors)
 $\therefore \vec{a} \wedge \vec{c} = 60^\circ$ and $\vec{a} \wedge \vec{b} = 90^\circ$
 $\therefore |\alpha - \beta| = 30^\circ$

65. $\int \frac{3x^{13} + 2x^{11}}{(2x^4 + 3x^2 + 1)^4} dx$
 $\int \frac{\left(\frac{3}{x^3} + \frac{2}{x^5}\right) dx}{\left(2 + \frac{3}{x^2} + \frac{1}{x^4}\right)^4}$
 Let $\left(2 + \frac{3}{x^2} + \frac{1}{x^4}\right) = t$
 $-\frac{1}{2} \int \frac{dt}{t^4} = \frac{1}{6t^3} + C \Rightarrow \frac{x^{12}}{6(2x^4 + 3x^2 + 1)^3} + C$

66. A.M. \geq G.M.
 $\frac{\sin^4 \alpha + 4 \cos^4 \beta + 1 + 1}{4} \geq (\sin^4 \alpha \cdot 4 \cos^4 \beta \cdot 1 \cdot 1)^{\frac{1}{4}}$
 $\sin^4 \alpha + 4 \cos^2 \beta + 2 \geq 4\sqrt{2} \sin \alpha \cos \beta$ given that $\sin^4 \alpha + 4 \cos^4 \beta + 2 = 4\sqrt{2} \sin \alpha \cos \beta$
 \Rightarrow A.M. = G.M. $\Rightarrow \sin^4 \alpha = 1 = 4 \cos^4 \beta$
 $\sin \alpha = \pm 1, \cos \beta = \pm \frac{1}{\sqrt{2}}$, As $\alpha, \beta \in [0, \pi]$
 $\Rightarrow \sin \alpha = 1, \cos \beta = \pm \frac{1}{\sqrt{2}}$
 $\Rightarrow \sin \beta = \frac{1}{\sqrt{2}}$ as $\beta \in [0, \pi]$
 $\cos(\alpha + \beta) - \cos(\alpha - \beta) = -2 \sin \alpha \sin \beta$
 $= -\sqrt{2}$

67. $\frac{dy}{dx} = \frac{x^2 - 2y}{x}$ (Given)
 $\frac{dy}{dx} + 2\frac{y}{x} = x$
 I.F. = $e^{\int \frac{2}{x} dx} = x^2$
 $\therefore y \cdot x^2 = \int x \cdot x^2 dx + C$

$$= \frac{x^4}{y} + C$$

Hence b passes through (1, -2) $\Rightarrow C = -\frac{9}{4}$

$$\therefore yx^2 = \frac{x^4}{4} - \frac{9}{4}$$

Checking options, only option (B) satisfies.

68. Direction Ratio of line are 2, 1, -2
Normal vector of plane is $\hat{i} - 2\hat{j} - k\hat{k}$

$$\sin \alpha = \frac{(2\hat{i} + \hat{j} - 2\hat{k}) \cdot (\hat{i} - 2\hat{j} - k\hat{k})}{3\sqrt{1+4+k^2}}$$

$$\sin \alpha = \frac{2k}{3\sqrt{k^2+5}} \quad \dots\dots\dots(1)$$

$$\cos \alpha = \frac{2\sqrt{2}}{3} \quad (\text{Given}) \quad \dots\dots\dots(2)$$

Using $\sin^2 \alpha + \cos^2 \alpha = 1 \Rightarrow k^2 = \frac{5}{3}$

69. $\lim_{x \rightarrow \infty} \sum_{r=1}^{2n} \frac{n}{n^2 + r^2}$
 $\lim_{x \rightarrow \infty} \sum_{r=1}^{2n} \frac{1}{n \left(1 + \frac{r^2}{n^2}\right)}$ Using D.I. as limit of sum, we get

$$= \int_0^2 \frac{dx}{1+x^2} = \tan^{-1} 2$$

70. Let w denotes probability that outcome 5 or 6 $\left(w = \frac{2}{6} = \frac{1}{3}\right)$

Let, L denotes probability that outcome 1, 2, 3, 4 $\left(L = \frac{4}{6} = \frac{2}{3}\right)$

Expected Gain/Loss

$$= w \times 100 + Lw(-50 + 100) + L^2w(-50 - 50 + 100) + L^3(-150)$$

$$= \frac{1}{3} \times 100 + \frac{2}{3} \cdot \frac{1}{3} (50) + \left(\frac{2}{3}\right)^2 \left(\frac{1}{3}\right) (0) + \left(\frac{2}{3}\right)^3 (-150) = 0$$

71. Let the line be $\frac{x}{a} + \frac{y}{b} = 1$

$$(-3, 4) = \left(\frac{a}{2}, \frac{b}{2}\right)$$

$$a = -6, b = 8$$

equation of line is

$$4x - 3y + 24 = 0$$

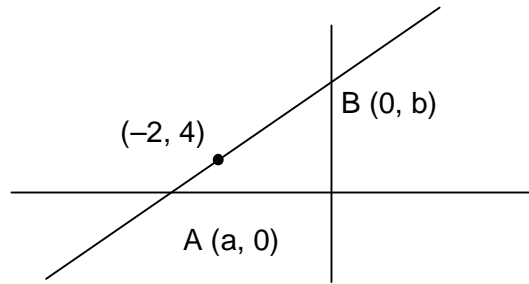

72. Let m – men, 2 – women

$${}^m C_2 \times 2 = {}^m C_1 \cdot {}^2 C_1 \cdot 2 + 84$$

$$m^2 - 5m - 84 = 0 \Rightarrow (m - 12)(m + 7) = 0$$

$$m = 12$$

73. $y = x^2 - 5x + 5$

$$\frac{dy}{dx} = 2x - 5 = 2 \Rightarrow x = \frac{7}{2}$$

$$\text{at } x = \frac{7}{2}, y = \frac{-1}{4}$$

$$\text{Equation of tangent at } \left(\frac{7}{2}, \frac{-1}{4}\right) \text{ is } 2x - y - \frac{29}{4} = 0$$

Now check options

$$x = \frac{1}{8}, y = 7$$

74. All four points are coplanar so

$$\begin{vmatrix} 1 - \lambda^2 & 2 & 0 \\ 2 & -\lambda^2 + 1 & 0 \\ 2 & 2 & -\lambda^2 - 1 \end{vmatrix} = 0$$

$$(\lambda^2 + 1)^2 (3 - \lambda^2) = 0$$

$$\lambda = \pm\sqrt{3}$$

75. $|z_1| = 9, |z_2 - (3 + 4i)| = 4$

$$C_1(0, 0) \text{ radius } r_1 = 9$$

$$C_2(3, 4), \text{ radius } r_2 = 4$$

$$C_1 C_2 = |r_1 - r_2| = 5$$

\therefore Circle touches internally

$$\therefore |z_1 - z_2|_{\min} = 0$$

76. General term $T_{r+1} = {}^{60} C_r \cdot 7^{\frac{60-r}{5}} \cdot 3^{\frac{r}{10}}$

\therefore for rational term, $r = 0, 10, 20, 30, 40, 50, 60$

\Rightarrow number of rational terms = 7

\therefore number of irrational terms = 54

77. $x^2 = 8y$
 $\Rightarrow \frac{dy}{dx} = \frac{x}{4} = \tan \theta$
 $\therefore x_1 = 4 \tan \theta$
 $y_1 = 2 \tan^2 \theta$
 Equation of tangent :-
 $y - 2 \tan^2 \theta = \tan \theta (x - 4 \tan \theta)$
 $\Rightarrow x = y \cot \theta + 2 \tan \theta$

78. A \rightarrow opted NCC
 B \rightarrow opted NSS
 $\therefore P(\text{neither A nor B}) = \frac{10}{60} = \frac{1}{6}$

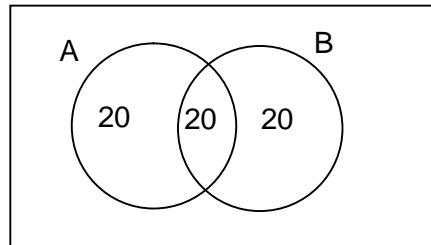

79. Mean $\bar{x} = 4, \sigma^2 = 5.2, n = 5, x_1 = 3, x_2 = 4 = x_3$
 $\sum x_i = 20$
 $x_4 + x_5 = 9 \dots\dots\dots(i)$
 $\frac{\sum x_i^2}{x} - (\bar{x})^2 = \sigma^2 \Rightarrow \sum x_i^2 = 106$
 $x_4^2 + x_5^2 = 65 \dots\dots\dots(ii)$
 Using (i) and (ii) $(x_4 - x_5)^2 = 49$
 $|x_4 - x_5| = 7$

80. $|A| = \begin{vmatrix} 1 & \sin \theta & 1 \\ -\sin \theta & 1 & \sin \theta \\ -1 & -\sin \theta & 1 \end{vmatrix}$
 $= 2(1 + \sin^2 \theta)$
 $\theta \in \left(\frac{3\pi}{4}, \frac{5\pi}{4}\right) \Rightarrow \frac{1}{\sqrt{2}} < \sin \theta < \frac{1}{\sqrt{2}}$
 $\Rightarrow 0 \leq \sin^2 \theta < \frac{1}{2}$
 $\therefore |A| \in [2, 3)$

81. Slope of AB = $\frac{-h}{k}$
 Equation of AB is $hx + ky = h^2 + k^2$
 $A\left(\frac{h^2 + k^2}{h}, 0\right), B\left(0, \frac{h^2 + k^2}{k}\right)$
 As, AB = 2R
 $\Rightarrow (h^2 + k^2)^3 = 4R^2 h^2 k^2$
 $\Rightarrow (x^2 + y^2)^3 = 4R^2 x^2 y^2$

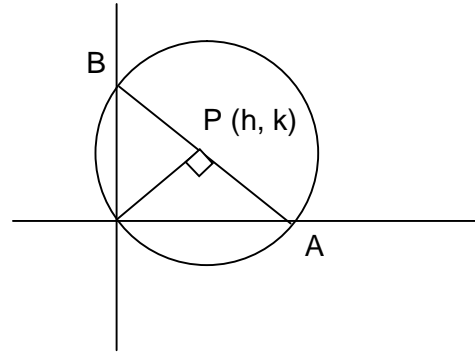

82.
$$\begin{vmatrix} \lambda - 1 & 2 & 2 \\ 1 & 2 - \lambda & 1 \\ 1 & 1 & 1 \end{vmatrix} = 0$$

 $\Rightarrow (\lambda - 1)^3 = 0 \Rightarrow \lambda = 1$

83. $f'(x) = 3x^2 - 6(a - 2)x + 3a$
 $f'(x) \geq 0 \forall x \in (0, 1]$
 $f'(x) \leq 0 \forall x \in [1, 5)$
 $\Rightarrow f'(x) = 0$ at $x = 1 \Rightarrow a = 5$
 $f(x) - 14 = (x - 1)^2 (x - 7)$
 $\frac{f(x) - 14}{(x - 1)^2} = x - 7$
 Hence root of equation $\frac{f(x) - 14}{(x - 1)^2} = 0$ is 7.

84. $A = \left\{x \in \mathbb{Z} : 2^{(x+2)(x^2-5x+6)} = 1\right\}$
 $2^{(x+2)(x^2-5x+6)} = 2^0 \Rightarrow x = -2, 2, 3$
 $A = \{-2, 2, 3\}$
 $B = \{x \in \mathbb{Z} : -3 < 2x - 1 < 9\}$
 $B = \{0, 1, 2, 3, 4\}$
 Hence, $A \times B$ has 15 elements.
 So number of subsets of $A \times B$ is 2^{15} .

85. $2 \cdot {}^n C_5 = {}^n C_4 + {}^n C_6$
 $2 \cdot \frac{|n|}{|5n-5|} = \frac{|n|}{|4n-4|} + \frac{|n|}{|6n-6|}$
 $\frac{2}{5} \cdot \frac{1}{n-5} = \frac{1}{(n-4)(n-5)} + \frac{1}{30}$
 $n = 14$ satisfying equation.

86. $m_{S'B} \cdot m_{S'B} = -1$
 $b^2 = a^2 e^2$ (i)
 $\frac{1}{2} S'B \cdot SB = 8$
 $a^2 e^2 + b^2 = 16$
(ii)
 $b^2 = a^2 (1 - e^2)$
(iii)
 using (i), (ii), (iii) $a = 4$
 $b = 2\sqrt{2}$
 $e = \frac{1}{\sqrt{2}}$
 $\therefore l(L.R) = \frac{2b^2}{a} = 4$

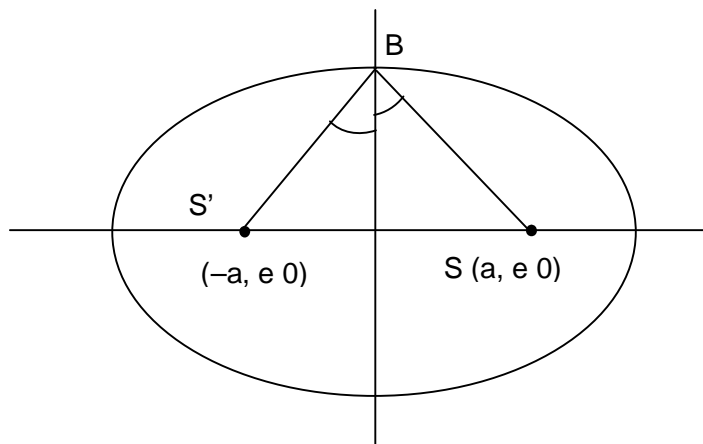

87. $\tan 30^\circ = \frac{x}{y} \Rightarrow y = \sqrt{3} x$ (i)
 $\tan 60^\circ = \frac{25 + x + 25}{y}$
 $\Rightarrow \sqrt{3} y = 50 + x$
 $\Rightarrow 3x = 50 + x$
 $\Rightarrow x = 25 \text{ m}$
 \therefore Height of cloud from surface
 $= 25 + 25 = 50 \text{ m}$

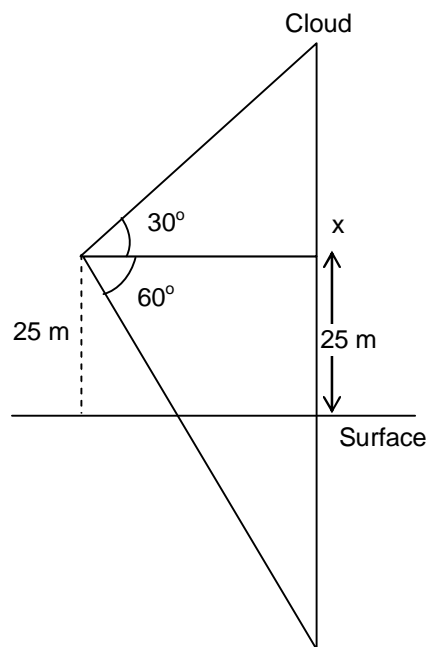

88.

p	q	$\sim p$	$\sim p \rightarrow q$	$\sim(\sim p \rightarrow q)$	$(\sim p \wedge \sim q)$
T	T	F	T	F	F
F	T	T	T	F	F
T	F	F	T	F	F
F	F	T	F	T	T

89.
$$S = \left(\frac{3}{4}\right)^3 + \left(\frac{6}{4}\right)^3 + \left(\frac{9}{4}\right)^3 + \left(\frac{12}{4}\right)^3 + \dots \dots \dots 15 \text{ term}$$

$$= \frac{27}{64} \sum_{r=1}^{15} r^3$$

$$= \frac{27}{64} \left[\frac{15(15+1)}{2} \right]^2$$

$$= 225 K \text{ (Given in question)}$$

$$K = 27$$

90. Expression is always positive if $2m + 1 > 0 \Rightarrow m > -\frac{1}{2}$
 and $D < 0 \Rightarrow m^2 - 6m - 3 < 0$
 $3 - \sqrt{12} < m < 3 + \sqrt{12} \dots \dots \dots \text{(iii)}$
 \therefore Common interval is $3 - \sqrt{12} < m < 3 + \sqrt{12}$
 \therefore Integral value of $m \{0, 1, 2, 3, 4, 5, 6\}$